

Danfoss
GX™ 850M
Manual

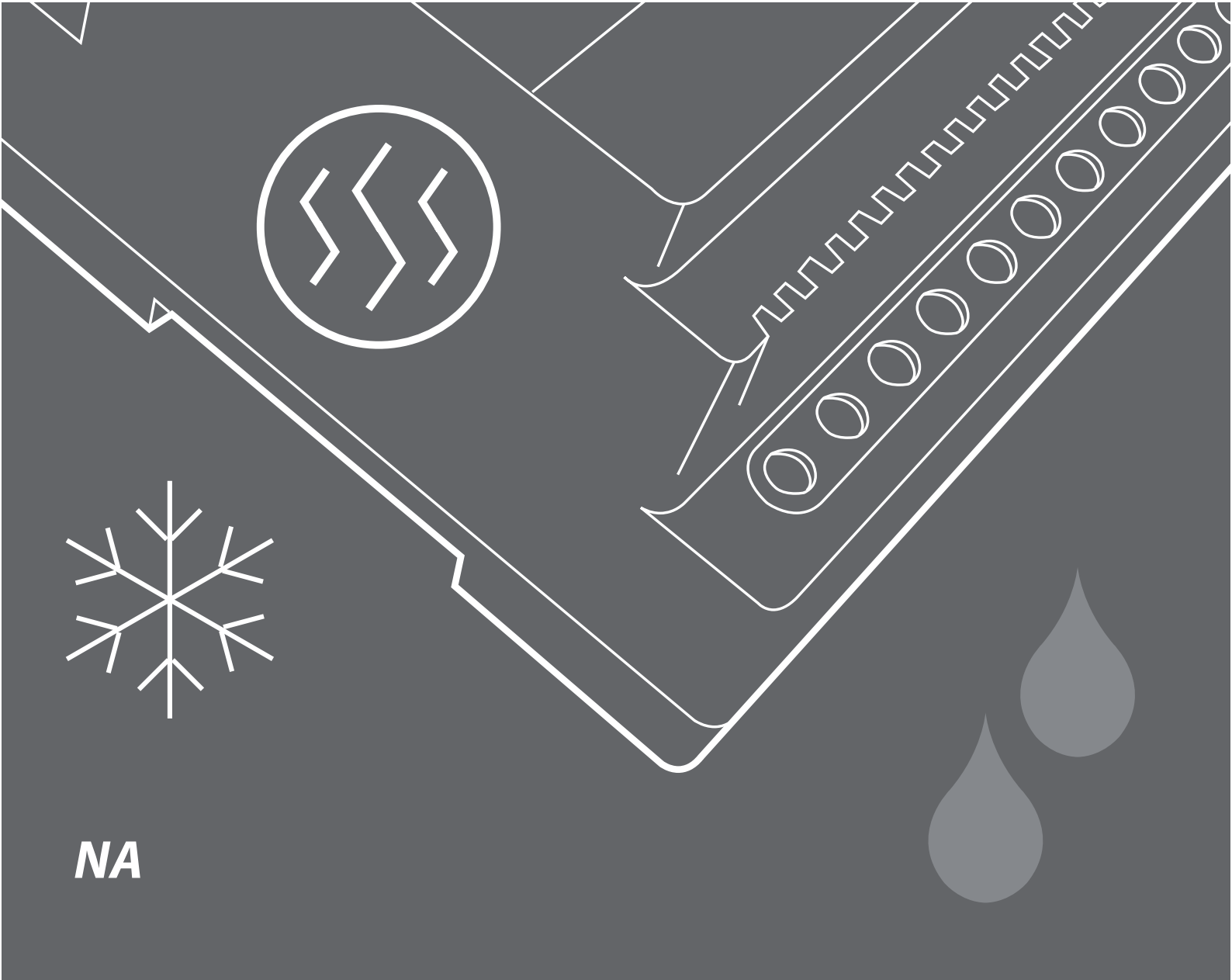

Table of Contents

1: User Manual

System overview	3
General use	5
Buttons	5
Display.	5
Menu system.	6
Possible alarms during operation	
Clogged drain	7
Missing sensor	7
New added sensor	7
Sensor malfunction.	7
Changing parameters and performance of systems.	8
Roof system	8
Ground system	9

2: Installer Manual

System overview	10
Placement	11
Connection steps for system	11
Installation steps for system/systems	15
General	15
Installation of roof system	16
Installation of ground system	17
Installation of combi system	18
Installation of dual system	20
Modification of system(s)	22

3: Technical Specification

Technical data	25
Factory settings (Roof system)	26
Factory settings (Ground system)	26

4: Appendix :

A: Menu system.	27
B: How it works	32
Roof system	32
Ground system	33
Security and energy consumption	34
C: PSU and feeder cable	35
Ground system	35
Roof system	35

System overview

The GX™ 850M system is capable of keeping outdoor areas free of ice and snow. The GX™ 850M can handle up to 2 independent areas, in any of the following combinations:

- **Single roof system**

To keep gutters, valley gutters and down pipes free of ice and snow, and to prevent ice dams from causing damage. It is also possible to use the roof system to reduce/remove the snow weight from a roof. (Roof system A)

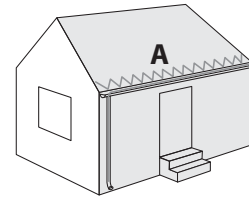

- **Single ground system**

To keep areas like parking areas, paths, garage entrances, steps, ramps, roadways and bridges free of ice and snow. (Ground systems A)

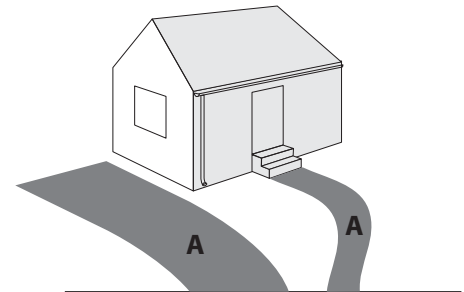

- **1 ground system and 1 roof system**

(combi system)

Consists of 1 single roof system A and 1 single ground system B.

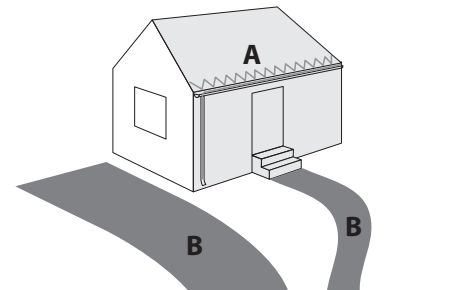

- **2 roof systems** (dual system)

Consists of 2 x "Single roof systems (A and B)".

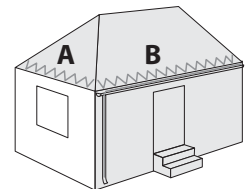

- **2 ground systems** (dual system)

Consists of 2 x "Single ground systems (A and B)".

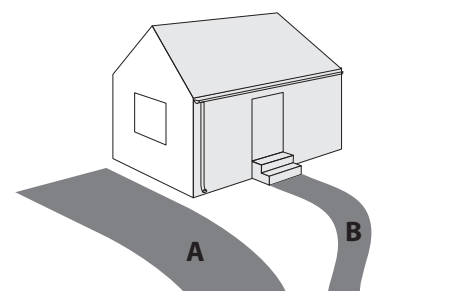

When more than 1 area is controlled by the GX™ 850M system, it is also possible to prioritize the areas. Prioritizing makes it possible to operate 2 areas, even if the required power for 2 areas is not present.

The GX™ 850M is fully automatic and operated digitally by means of the intelligent sensors located in the heated terrain. Each sensor measures both temperature and moisture, and the system turns the heating elements on and off based on these readings. By combining moisture and temperature readings, the system is able to save around 75% energy compared to systems which only measure temperature readings. The digital sensors used for the GX™ 850M also provide the most exact readings when compared with corresponding analogue systems. The result is optimum functionality and low energy consumption.

A typical installation consists of:

- **Controller unit** (only one)

This is the device which, based on the measurements from the sensors, decides when to heat the connected area(s).



- **Power supply** (one or more)

The power supply delivers power to the controller unit and the connected sensors.

- **Ground sensor** (one or more)

At least 1 ground sensor is needed for each ground area, but to get the best performance of a system, 2 or more sensors are recommended. For more information please refer to the sensor manual.



- **Roof sensor** (one or more)

At least 1 roof sensor is needed for each roof area, but for complex roof constructions, 2 or more sensors are recommended. For more information please refer to the sensor manual.





For more information about the ice and snow melting function of the GX™ 850M, please refer to: Appendix B: "How it works".

General use

The GX™ 850M is operated via 3 buttons and an alpha numeric display capable of displaying information in various languages.

Buttons

The functions of the 3 buttons are:

-  Info Shows additional information / help (only active when lit)
-  Next Next menu entry / next line / next letter
-  Enter Confirm / select

Besides the normal function of the buttons, some special combinations are important to the user:

Return to home:

Return to home of menu system

Hold for 2 seconds:



Master reset:



Restore factory defaults AND delete installed systems.
(In case of unsolvable problems due to a wrong choice of language, etc.)

Hold for 8 seconds:



Display

The following icons have a special meaning:

-  This **animated icon** is shown, when the system is heating.
If icon is **blinking** the system wants to heat, but is paused (system has low priority)
-  This icon is shown, when the system has detected moisture, and the temperature is above the melting temperature.
-  This icon is shown, when the system has detected snow or ice, and the temperature is below the melting temperature.

The GX™ 850M can simultaneously control up to 2 different systems. These 2 systems are referred to as **System A** and **System B**. The GX™ 850M gives the user the opportunity to view the current status of the systems. The status can be shown in 2 different ways.

Combined view (default):

The combined view shows the status of both systems at the same time. **System A** is shown on the upper display line, and **System B** is shown on the lower display line. This view gives the user a quick overview of all the systems.

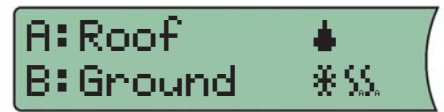

Flipped view:

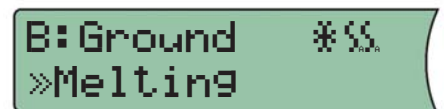

The flipped view shows the status of one system at a time. The status of each system is shown for 5 seconds.

This view gives the user more detailed information about each system.



The user can always press  to get more information about the current status irrespective of view selected.

Menu system

The menu system is navigated by the keys  and .

No matter if the GX™ 850M controls one or two systems, the look and use of the menu system is always the same. This is obtained by making the entry to each system in the main menu. The possibilities and settings for each system are first accessible after the user has selected the desired system.

To the right is given an example of the main menu and the menus for **System A** and **System B**.

 Please notice, that only a few of the menus for each system are shown!

For a complete overview of the menu system, please refer to: Appendix A: "Menu system".

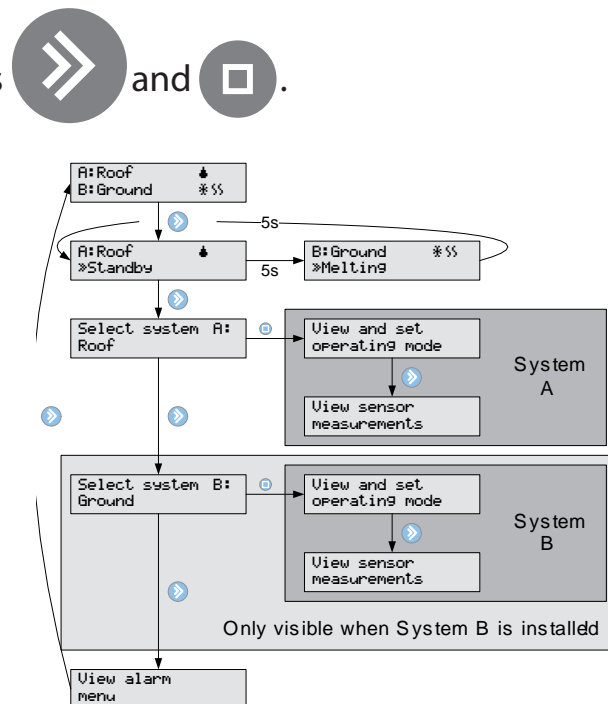

Possible alarms during operation

Clogged drain	
Description:	<p>When clogged drain warning has been enabled, the system constantly has been detecting moisture for 14 days.</p> <p> If the GX™ 850M controls more than 1 system, and prioritizing has been enabled, the time before clogged drain warning for the down-prioritized system, can be much longer. The time is only updated when the system actually is allowed to heat the area (e.g. the higher priority system is not heating)</p>
Solution:	<ul style="list-style-type: none">- Check gutter and down pipes for any obstacles preventing the melting water to flow away.- Check if sensors are covered with dirt.

Missing sensor	
Description:	<p>When the connection to a sensor is lost, the GX™ 850M alerts the user. At the same time the GX™ 850M automatically switches the system to “Constant Off” mode, and user interaction with the GX™ 850M is needed.</p>
Solution:	<ul style="list-style-type: none">- Acknowledge error and go to “Installer Site” in the menu system and select “Change System”.- Contact your local installer to get a replacement.

New sensor added	
Description:	<p>When a new sensor is added, the GX™ 850M alerts the user and at the same time automatically switches to “Constant Off” mode. User interaction is needed in order to correct the error.</p>
Solution:	<p>Acknowledge error and go to “Installer Site” in the menu system and select “Change System”.</p>

Sensor malfunction	
Description:	<p>When something is wrong with the readings from connected sensors to the GX™ 850M, an alarm is raised.</p> <p> Not all error prone sensors can be discovered using this feature!</p>
Solution:	<ul style="list-style-type: none">- Acknowledge error and go to “Installer Site” in the menu system and select “Change System”.- Contact your local service centre to get a replacement.

Changing parameters and performance of systems

Several parameters for each system can be changed during and after the installation. For a complete understanding of how these parameters affect the performance of the roof and ground system, please refer to Appendix B: "How it works".



Only change the GX™ 850M parameters if you are aware of the effects of your actions.

Reference: Appendix A: Installer menu

Roof system

Melting temperature

Changing the melting temperature will affect when the system is activated in case of moisture and low temperatures.

The factory setting is 35 °F (1.5°C).

This means that the heating system will be activated if the temperature falls below 29 °F (1.5°C) and moisture is detected.

Moisture level

The "moisture level" decides when the system detects moisture.

The factory setting is 50 (on a scale from 5 to 95).

The lower the setting, the more sensitive the system is to moisture.

Post-heat

Once the sensor has detected that the roof/gutter is dry and free of ice and snow the system will keep heating for another hour (default). If you wish to increase/decrease this time see capital A: Installer menu.

The factory setting is 1 hour (on a scale from 0 to 9 hours)

Priority

When using the GX™ 850M as a dual or combi system, it is possible to prioritize the systems. When the priority of 2 systems is equal, both systems can heat at the same time. If the priority of the 2 systems differs, and both systems want to heat, only the system with the highest priority is allowed to heat.

The factory setting is 1 (highest priority) for all systems.

Clogged drain

It is possible to enable and disable the "Clogged drain warning".

The factory setting is "Warning On".

System and sensor name

It is possible to change the names of the system and connected sensors (see capital A: Installer menu).

Ground system

Melting temperature

Changing the melting temperature will affect when the system is activated in case of moisture and low temperatures.

The factory setting is 39°F (4°C).

This means that the heating system will be activated if the temperature falls below 4°C and moisture is detected.

Standby temperature (maintained ground temperature)

The higher the standby temperature the faster the system will be able to melt ice and snow.

On the other hand the higher the standby temperature the higher the running costs. So, determining the standby temperature is a trade-off between fast melting or low running costs. *The factory setting is 27°F (-3 C°).*

Moisture level

The “moisture level” decides when the system detects moisture.

The factory setting is 50 (on a scale from 5 to 95).

The lower the setting, the more sensitive the system is to moisture.

Post-heat

Once the sensor has detected that the roof/gutter is dry and free of ice and snow the system will keep heating for another hour (default). If you wish to increase/decrease this time see capital A: Installer menu.

The factory setting is 1 hour (on a scale from 0 to 9 hours)

Priority

When using the GX™ 850M as a dual or combi system, it is possible to prioritize the systems. When the priority of 2 systems is equal, both systems can heat at the same time. If the priority of the 2 systems differs, and both systems want to heat, only the system with the highest priority is allowed to heat.

The factory setting is 1 (highest priority) for all systems.

Clogged drain

It is possible to enable and disable the “Clogged drain warning”.

The factory setting is “Warning On”.

System and sensor name

It is possible to change the names of the system and connected sensors.

Installer Manual

System overview

The GX™ 850M can handle up to 2 independent areas, in any of the following combinations:

- **Single roof system**
(1 system, 1-4 roof sensors)
- **Single ground system**
(1 system, 1-4 roof sensors)
- **1 ground system and 1 roof system** (combi system)
(2 systems, 2-4 sensors total, minimum 1 sensor per system)
- **2 roof systems** (dual system)
(2 systems, 2-4 sensors total, minimum 1 sensor per system)
- **2 ground systems** (dual system)
(2 systems, 2-4 sensors total, minimum 1 sensor per system)

When more than 1 area is controlled by the GX™ 850M system, it is also possible to prioritize the areas. Prioritizing makes it possible to operate 2 areas, even if the needed power for 2 areas is not present.

A typical ice and snow melting system consists of:

- **GX™ 850M**
 - Only 1 GX™ 850M is allowed on the Devibus™
- **Power supply**
 - More power supplies can be connected in parallel (if needed)
 - Be aware of maximum number of sensors on each power supply
(Refer to Technical Specification for power demand of sensors)
- **Ground and/or roof sensor(s)**
 - Be aware of maximum number and cable length of sensors on each power supply
(Refer to sensor manual for a more detailed description)

Placement

The GX™ 850M and power supply are designed for DIN rail mounting. When mounting please be aware of the following conditions:



The GX™ 850M is designed and approved to operate in the temperature range 14°F (-10°C) to 104°F (40°C).



The GX™ 850M is only NEMA 1 protected, thus not water resistant.



The installer must ensure proper enclosure of the GX™ 850M according to national standards (electrical safety).

Connection steps for system



Only authorized personnel is allowed to install the GX™ 850M.

When wiring up the GX™ 850M and sensors, please be aware of the following conditions:



When the GX™ 850M is used in a dual system configuration, it is preferable that each sensor bus (Devibus™) can be connected and disconnected via switches. During the installation of a dual system, each system must be connected one at a time.



Be aware of maximum allowable power drain from power supply to sensors.

Below is shown the recommended order of the installation. Please refer to Figure A for connection of GX™ 850M and refer to Figure B-G for a guideline to connect the heating elements to GX™ 850M.

1. Connect heating cables to the GX™ 850M
 - Please notice that a single system ALWAYS uses the **System A** output relay
 - When using external power relay, please refer to the connection diagrams.
2. Connect the power supply to the GX™ 850M
 - Do not connect the power supply to mains yet
3. Connect sensors to the Devibus™
 - When used as a dual system, only the sensors for **System A** can be connected. For connection of **System B** please refer to chapter: "Installation of dual system".
4. Connect the power supply to mains.

Schematic Diagram

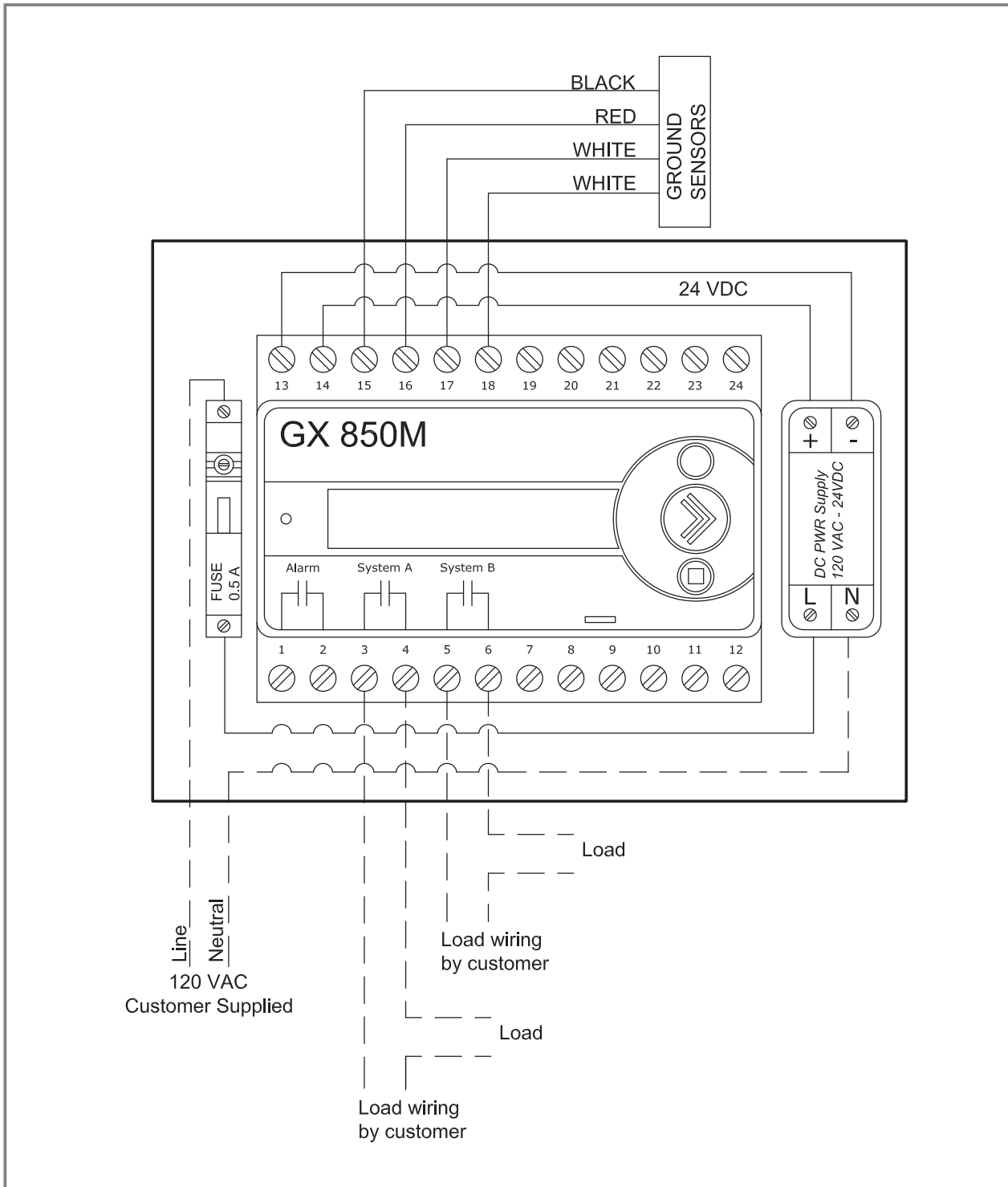

The dry contact relays A and B inside the GX850M are used to switch to the voltage of your choice. (120VAC Maximum)

The diagrams on the opposite page show typical applications. (The ground wire is not shown)

Typical Applications

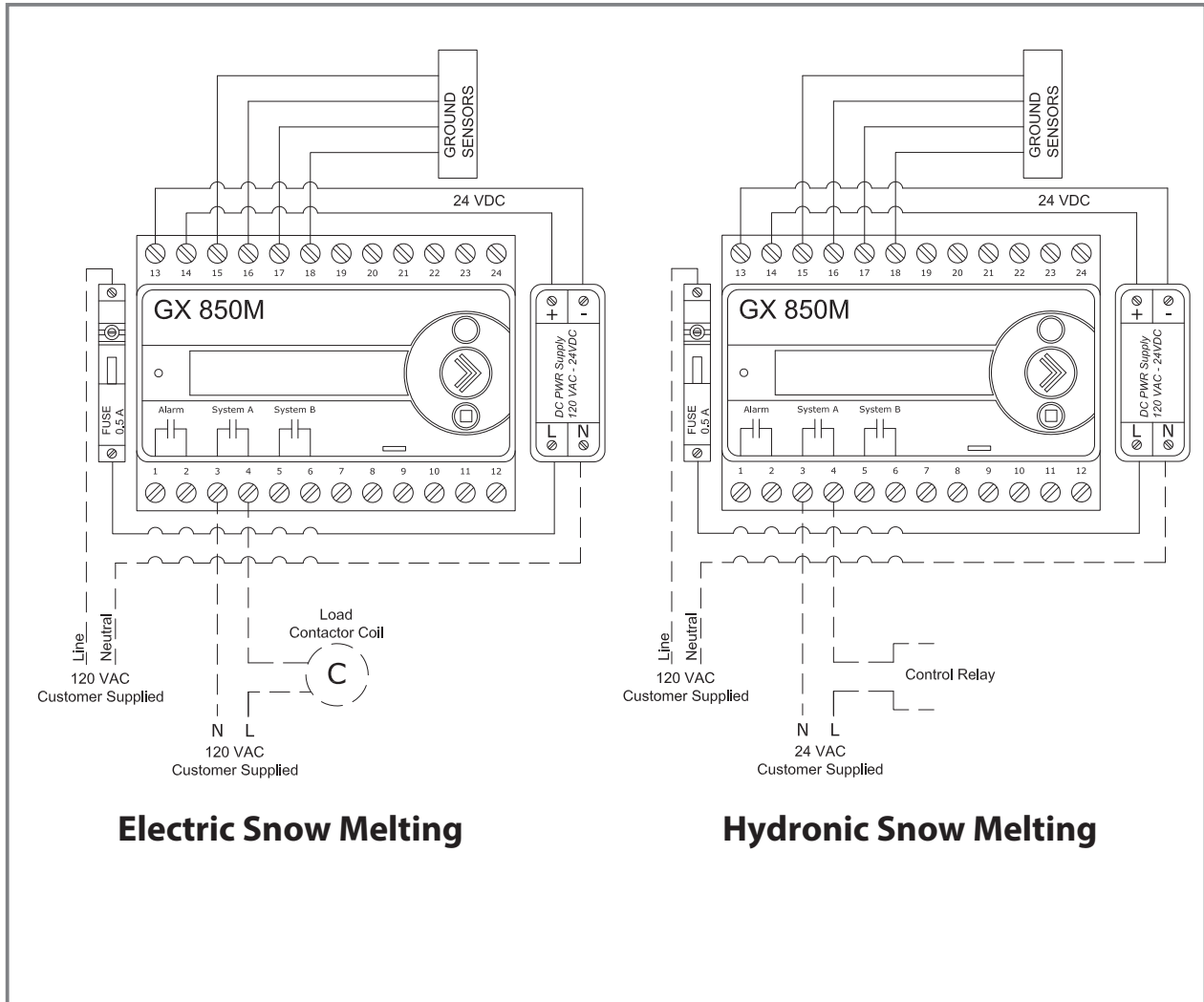

CAUTION!

It is important that this equipment is installed only by qualified electricians who are familiar with the proper sizing, installation, construction and operation of outdoor heating systems and the hazards involved. The GX system is designed for outdoor ice and snow melting applications only.

NOTE!

The installation shall be in accordance with the manufacturer's instructions and national and local electrical codes. The installation shall be in accordance with part 426, American National Standard Institute / National Fire Protection Association (ANSI/NFPA70), National Electrical Code (NEC) and Canadian Electrical Code (CEC), part 1

Part Numbers

GX Snow Melting Controls

Part #	Description	Voltage
088L3415	GX850M Automatic Control Panel	120V



GX850M Automatic Control Panel

GX Snow Melting Accessories

Part #	Description
088L3051	Ground Sensors (Two per Package)
088L3052	Roof Sensor



Ground Sensor



Roof Sensor

Installation steps for system/systems

The installation of the GX™ 850M is very easy, and the user is guided through the installation process. The installation process differs a little depending on which kind and the number of systems to be installed.

Please follow the general description and finally select the installation scenario according to the system type.

Change setting with key: 

Accept setting with key: 

General

 Power on GX™ 850M

```
Welcome to  
GX 850 III
```

 Select language

```
Select language:  
English
```

System is being checked...

```
Checking system  
<----->
```

 Select system configuration

- **Roof system** (1 system)
- **Ground system** (1 system)
- **Combi system** (2 systems)
- **Dual system** (2 systems)

```
System size:  
1 system
```

The rest of the installation is divided into the system configurations; roof, ground, combi or dual, as listed above.

Installation of roof system

The installation of a GX™ 850M with 1 roof system has been selected.

It is optional if the sensors are connected to the GX™ 850M before power on or during the installation.



The system uses the output **System A**.

If sensors for System A are not connected - do it now!

Press  or wait...

System is being scanned to find type of connected sensors...



Select system type: Roof



Wait until correct number of sensors for **System A** is found.

Press  when all sensors are found...
System A is installed...

System is being checked...



Press  to configure **System A**.
(Naming sensors and changing factory settings)

Please refer to "Changing parameters and performance of systems" in "User Manual" for description of the configurable parameters.

If for some reason you do not wish to configure the system now you can press  to skip configuration of system .



Press  to end configuration.

Connect sensors:
System A

System A
Scanning...

System type:
Roof

1 Roof sensor
found. Accept?

System A!
Installed

Checking system
<----->

Config system:
System A

Press  to end
configuration.

Installation of ground system

The installation of a GX™ 850M with 1 ground system has been selected.

It is optional if the sensors are connected to the GX™ 850M before power on or during the installation.



The system uses the output **System A**.

If sensors for **System A** are not connected - do it now!

Press  or wait...

System is being scanned to find type of connected sensors...



Select system type: Ground



Wait until correct number of sensors for **System A** is found.

Press  when all sensors are found...
System A is installed...

System is being checked...



Press  to configure **System A**.
(Naming sensors and changing factory settings)

Please refer to "Changing parameters and performance of systems" in "User Manual" for description of the configurable parameters.

If for some reason you do not wish to configure the

system now you can press  to skip configuration of the system.



Press  to end configuration.

```
Connect sensors:  
System A
```

```
System A  
Scanning...
```

```
System type:  
Ground
```

```
3 Ground sensor  
found. Accept?
```

```
System A!  
Installed
```

```
Checking system  
<----->
```

```
Config system:  
System A
```

```
Press  to end  
configuration.
```

Installation of combi system

The installation of a GX™ 850M with 1 roof system and 1 ground system has been selected.

It is optional if the sensors are connected to the GX™ 850M before power on or during the installation.



The first installed system (**System A**) is using the output **System A**.
The second installed system (**System B**) is using the output **System B**.

It is freely selectable if System A should be the roof or ground system. However it is preferable that System A is the roof system, since System A is shown on the upper line of the display. Please refer to the description of the Display and Combined view in the user manual.

If sensors for **System A** are not connected - do it now!

Press  or wait...

System is being scanned to find type of connected sensors...

Select system type: Roof
(if roof system is preferred as **System A**)

Wait until correct number of sensors for **System A** is found.

Press  when all sensors are found...
System A is installed...

If sensors for **System B** are not connected - do it now!

Press  or wait...

System is being scanned to find type of connected sensors...

Select system type: Ground
(if ground system is preferred as **System B**)

```
Connect sensors:  
System A
```

```
System A  
Scanning...
```

```
System type:  
Roof
```

```
1 Roof sensor  
found. Accept?
```

```
System A!  
Installed
```

```
Connect sensors:  
System B
```

```
System B  
Scanning...
```

```
System type:  
Ground
```

Installer Manual

☞ Wait until correct number of sensors for **System B** is found.

Press  when all sensors for **System B** are found...
System B is installed...

System is being checked...

☞ Press  to select system to configure.

Press  to configure selected system.
(Naming sensors, changing factory settings and setting priorities)

Please refer to "Changing parameters and performance of systems" in "User Manual" for description of the configurable parameters.

☞ Press  to end configuration.

```
3 Ground sensors  
found. Accept?
```

```
System B  
Installed!
```

```
Checking system  
<----->
```

```
Config system:  
System A
```

```
Config system:  
System B
```

```
Press  to end  
Configuration.
```

Installation of dual system

The installation of a GX™ 850M with 2 roof systems or 2 ground systems has been selected.

It is **mandatory** that no sensors or only sensors for **System A** are connected to the the GX™ 850M before power up. Sensors for **System B** must be connected to the GX™ 850M during the installation steps. Connection of the sensors during installation can either be done using a switch on the DIN-rail or just connect sensor bus of **System B** to the already connected sensor bus of **System A**.



The first installed system (**System A**) is using the output **System A**.
The second installed system (**System B**) is using the output **System B**.

If sensors for **System A** are not connected - do it now!

Press  or wait...

```
Connect sensors:  
System A
```

System is being scanned to find type of connected sensors...

```
System A  
Scanning...
```

 Select system type

```
System type:  
Ground
```

 Wait until correct number of sensors for **System A** is found.

Press  when all sensors for **System A** are found...
System A is installed...

```
1 Ground sensor  
found. Accept?
```

```
System A  
Installed!
```

Connect sensors for **System B**.

Press  or wait...

```
Connect sensors:  
System B
```

System is being scanned to find type of connected sensors...

```
System B  
Scanning...
```

 Select system type

```
System type:  
Ground
```

Installer Manual

☞ Wait until correct number of sensors for **System B** is found.

Press  when all sensors for **System B** are found...
System B is installed...

System is being checked...

☞ Press  to select system to configure.

Press  to configure selected system.
(Naming sensors, changing factory settings and setting priorities)

Please refer to "Changing parameters and performance of systems" in "User Manual" for description of the configurable parameters.

☞ Press  to end configuration.

```
1 Ground sensor  
found. Accept?
```

```
System B  
Installed!
```

```
Checking system  
<----->
```

```
Config system:  
System A
```

```
Config system:  
System B
```

```
Press □ to end  
Configuration.
```

Modification of system(s)

It is possible to modify the installed systems on the GX™ 850M. The following modifications are possible:

- **Reactivate passive sensors**
- **Replace a malfunctioning sensor**
- **Add an extra sensor**

When the GX™ 850M cannot communicate with a sensor, the GX™ 850M reports the error: "Errors detected!". The GX™ 850M does not rely on malfunctioning sensors, and therefore the GX™ 850M makes the sensor passive. The passive sensor is no longer used for ice and snow detection - not even after a power cycle.



If the malfunctioning is caused by problems with the wiring, the failure can be fixed, and the sensor can be reactivated.



If the malfunctioning is caused by an error prone sensor, the error can be corrected by replacing the error prone sensor with a new sensor.



It is not possible to delete a passive sensor in a system. Passive sensors will remain in the systems until they are replaced with new sensors. The only way to delete a passive sensor (other than replacing it), is to make a **Master Reset** and reinstall the GX™ 850M (please refer to chapter: General use).

Reactivate passive sensors:

The given example is for a ground system.

 From the **installer menu** select **Change system**.

Press  to activate **Change system**.



```
Change system
```

The system is searching for connected sensors.

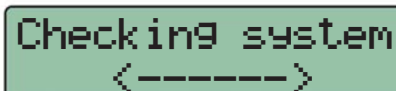

```
Checking system  
<----->
```

If any passive sensors are found, they are reactivated.
Message is shown for 3 seconds.

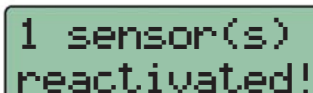

```
1 sensor(s)  
reactivated!
```

If no new sensors are found, it is reported to the user.
Message is shown for 3 seconds.

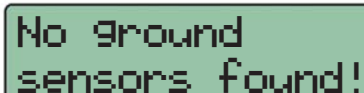



```
No ground  
sensors found!
```

Replace a malfunctioning sensor:

From the **installer** menu select **Change system**.
The system is searching for connected sensors.

The user selects the passive sensor, which should be replaced with a new one.

Press  to loop through the found passive sensors or to cancel replace sensor.

Press  when the correct passive sensor or "Cancel replace sensor?" is selected.

If the user selected a passive sensor to replace, the user should now select the new sensor.

Press  to loop through the found new sensors or to cancel replace sensor.

Press  when the correct new sensor to add is found or "Cancel replace sensor?" is selected.

If the user selected a new sensor to add, the replacing of the sensors is performed.

Add an extra sensor:

From the **installer** menu select **Change system**.
The system is searching for connected sensors.

Press  to loop through the found new sensors or to cancel add sensor.

Press  when the correct new sensor to add is found or "Cancel add sensor?" is selected.

```
Checking system  
<----->
```

```
Replace sensor:  
Sensor1  03FB2F
```

```
Replace sensor:  
Sensor2  03FC24
```

```
Cancel replace  
sensor?
```

```
Add sensor:  
ID:      03ABC1
```

```
Add sensor:  
ID:      03DEF1
```

```
Cancel replace  
sensor?
```

```
Sensor replaced!
```

```
Checking system  
<----->
```

```
Add sensor:  
ID:      03ABC1
```

```
Cancel add  
sensor?
```

If the user selected a new sensor to add, the sensor is added.



Sensor added!

Technical Specification

Technical data	
Voltage: • GX™ 850M • Power supply	24 VDC 120 VAC, 50/60 Hz
Enclosure Type and Dimensions	NEMA 4X Outer dimensions - 7" (H) x 7" (W) x 3" (D)
Mounting	Wall mounted - Indoors
Ambient temperature: • GX™ 850M • Roof sensor(s) • Ground sensor(s)	14°F (-10°C) to 104°F (+40°C) -58°F (-50°C) to 158°F (+70°C) * -22°F (-30°C) to 158°F (+70°C) *
Indication:	2 x 16-character illuminated display Alarm light (red) Lit info key (yellow)
Measurements: • GX™ 850M (without enclosure) • Roof sensor(s) • Ground sensor(s) • Tube ground sensor(s)	(Depth x Height x Width) 2.09" (53 mm) x 3.39" (86 mm) x 4.13" (105 mm) 0.6" (15 mm) x 0.93" (23.5 mm) x 8.5" (216 mm) D = 3.4" (23.5 mm); height = 2.9" (74 mm) D = 3.66" (93 mm); height = 3.86" (98 mm) *

* For further information on the sensors please refer to the sensor manual.

Factory settings (Roof system)

Function	Factory settings	Range/Options
Moisture level	50	5 to 95 (5 being the most sensitive to moisture)
Melting temperature	35°F (1.5°C)	32°F (0°C) to 50°F (10°C)
Post-heat	1 hour	0 to 9 hours
Clogged drain	On	On/off
System mode	Automatic	<ul style="list-style-type: none">• Automatic• Constant ON (manual timer)• Manually OFF

Factory settings (Ground system)

Function	Factory settings	Range/Options
Moisture level	50	5 to 95 (5 being the most sensitive to moisture)
Standby temperature	27°F (-3.0°C)	-4°F (-20°C) to 32°F (0°C)
Melting temperature	39°F (4.0°C)	34°F (1°C) to 50°F (10°C)
Post-heat	1 hour	0 to 9 hours
Clogged drain	On	On/off
System mode	Automatic	<ul style="list-style-type: none">• Automatic• Constant ON (manual timer)• Manually OFF

Appendix A: Menu system

Main menu

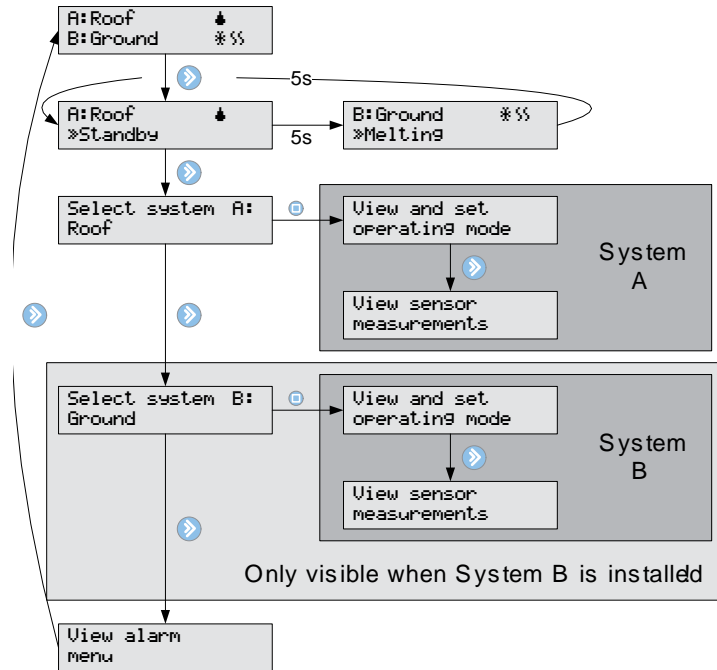

System menu

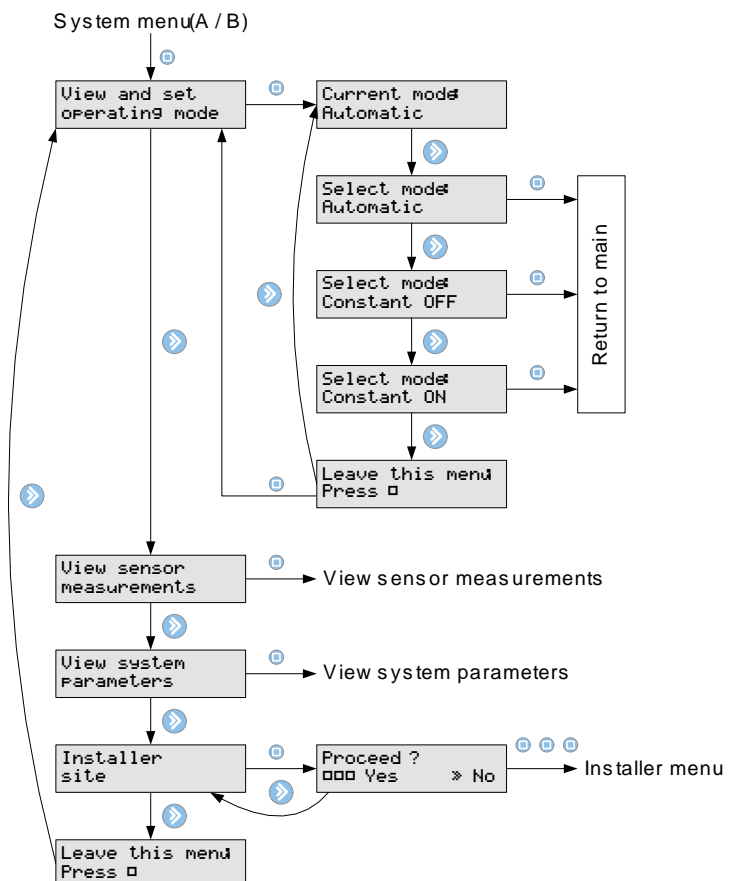

View sensor measurements

View sensor measurements
(Roof system)

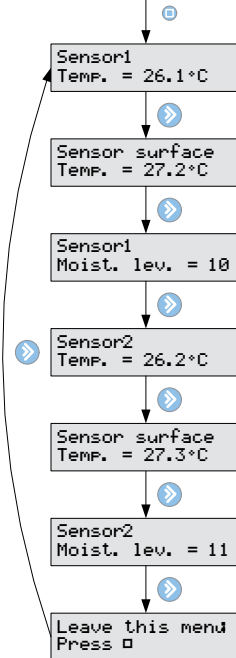

View system parameters
(Roof system)

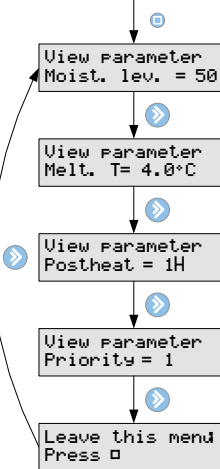

View sensor parameters

View sensor measurements
(Ground system)

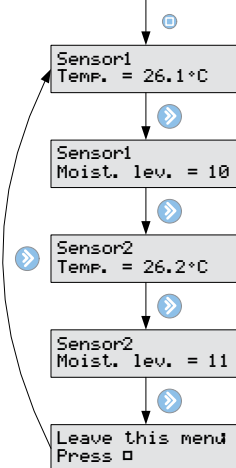

View system parameters
(Ground system)

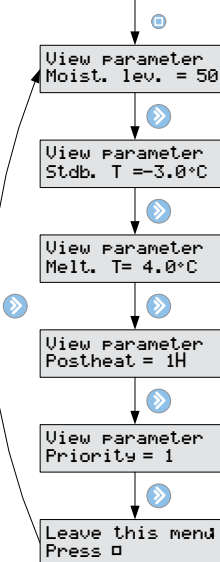

Appendix A

Installer menu

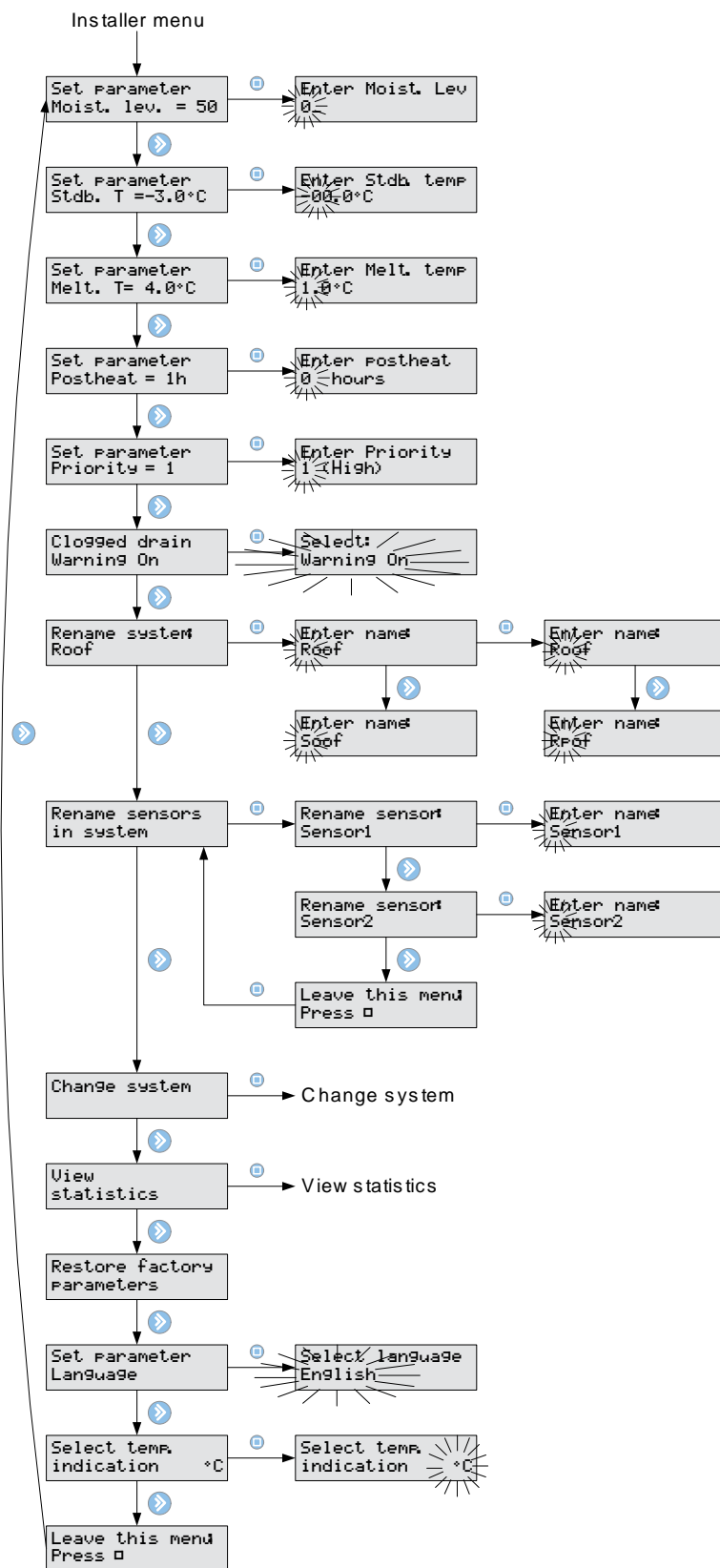

Appendix A

Change system

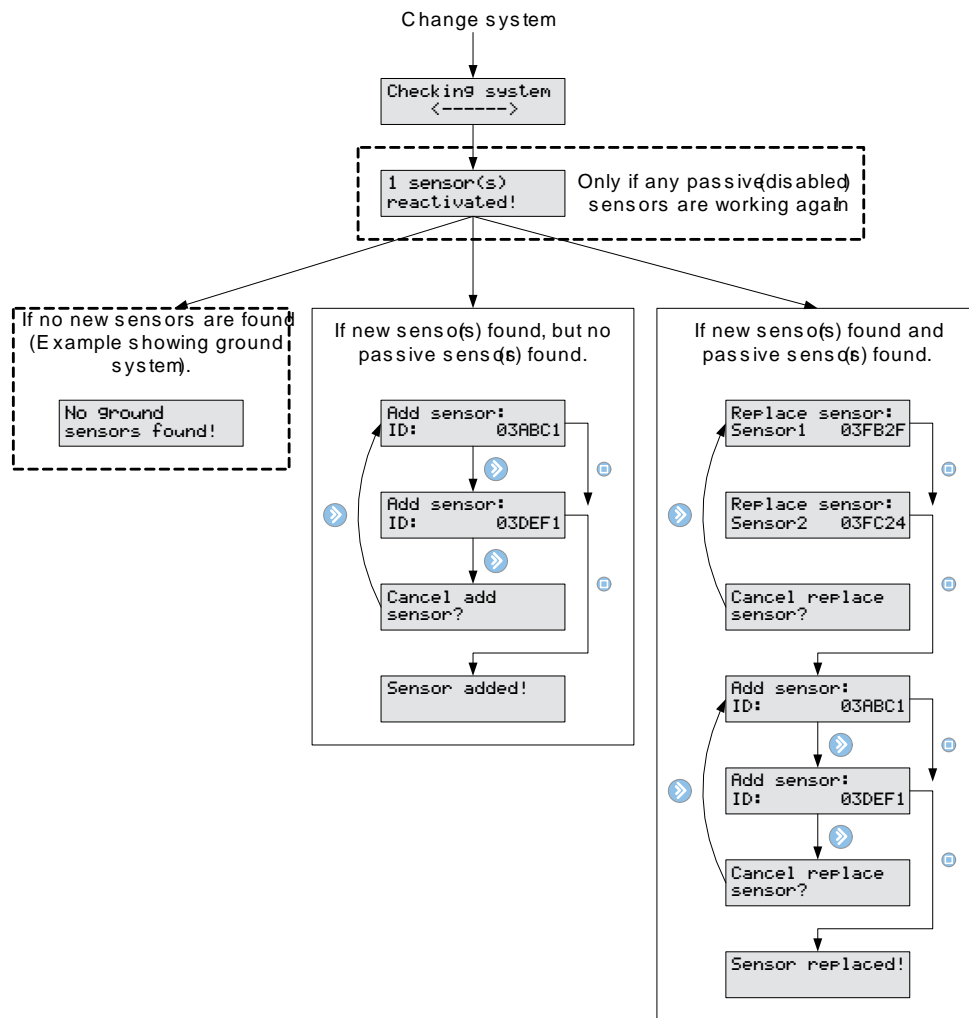

View statistic

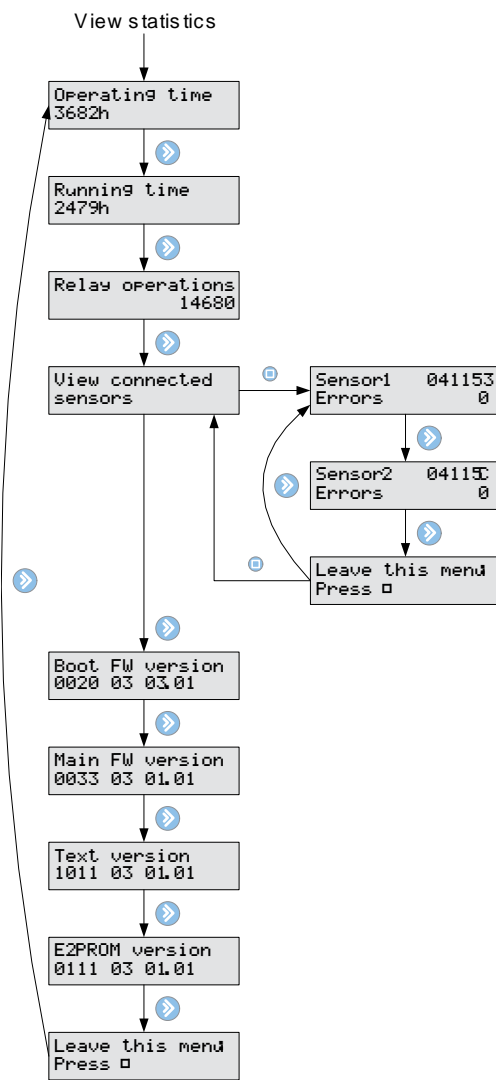

B: How it works

Roof system

The roof system is fully automated. It gathers information on moisture and temperature via digital sensors continuously. The sensors are placed on strategic spots in gutters or down pipes (for further information on the sensor please refer to the sensor manual). By combining measurements of both moisture and temperature a reliable detection of the situation is achieved. Hence it is known whether heating is required to prevent ice and snow from covering the roof area.

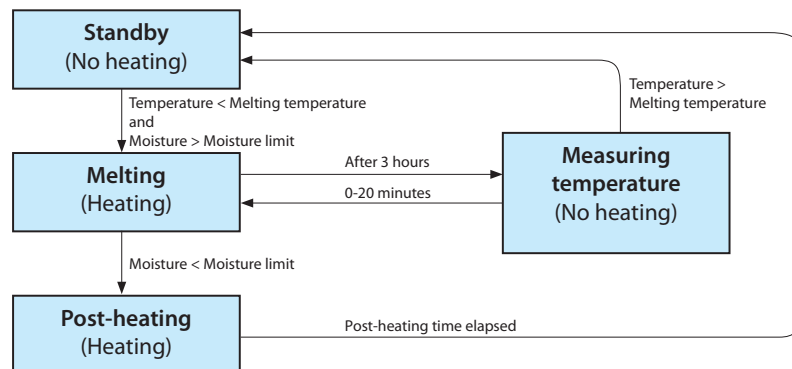

Standby

The system is on standby and awaits heating of the roof area. Heating of the roof area will start when the following conditions are fulfilled:

- Measured moisture is higher than the chosen setpoint for moisture.
- Measured temperature is lower than the chosen melting temperature.

Temperature and moisture are measured continuously by the sensors.

Melting ice and snow

The roof area is heated in periods of 3 hours. Within that period a decrease in moisture will stop the heating and activate post-heating. The post-heating function can be disabled.

Measuring temperature

The heating function is suspended every third hour meaning that the heating cables are turned off. This is done in order to allow the sensors to measure the temperature, without being influenced by the heated cables. The temperature measurement may last up to 20 minutes. If the measured temperature is higher than the chosen melting temperature the heating period is ended; if not, heating of the roof area is resumed after the temperature measurement.

Post-heating

If the reason for ending a heating period is a decrease of moisture to below the chosen level the post-heating period will start. Post-heating ensures that no ice and snow is left on the roof.

Ground system

The ground system is fully automated. It gathers information on moisture and temperature via digital sensors continuously. The sensors are placed on strategic spots on the ground area (for further information on the sensor please refer to the sensor manual).

By combining measurements of both moisture and temperature a reliable detection of the situation is achieved. Hence it is known whether heating is required to prevent ice and snow from covering the roof area.

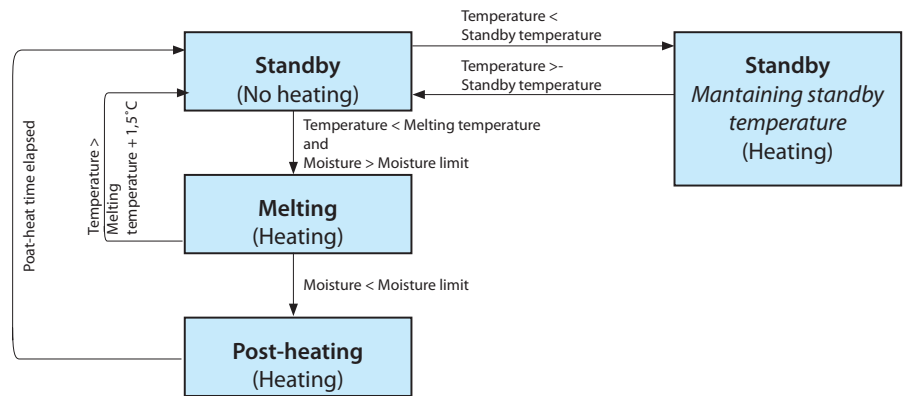

Standby

The system is on standby awaiting need for heating. If the measured temperature is below the chosen standby temperature the system will automatically heat the area in order to maintain the standby temperature.

Melting (heating) will start when the two following conditions are fulfilled:

- Measured moisture is higher than the chosen setpoint for moisture.
- Measured temperature is lower than the chosen melting temperature

Temperature and moisture are measured continuously by the sensors.

Melting ice and snow

As long as the measured temperature is lower than the chosen melting temperature heating of the ground area will be on. When the measured temperature reaches the chosen melting temperature and the measured moisture level is below the chosen limit, the post-heating function will be activated. The post-heating function can be disabled.

If moisture is detected on the ground area the system will continue to heat the area in order to maintain the melting temperature. It is, however, important to understand that even when the system is melting ice and snow it is not necessarily heating at all times. The heating will be turned on and off in accordance with the measured temperature in order to maintain a constant melting temperature.

If the temperature rises more than 35°F (1.5°C) above the chosen melting temperature the system will automatically stop heating the area irrespective of the moisture on the area.

Post-heating

If the reason for ending a heating period is a decrease of moisture to below the chosen level, the post-heating period will start. Post-heating ensures that no ice and snow is left on the ground.



If system priority is low, heating might be paused at any time!



The ground system uses heated sensors which under normal circumstances will hold a temperature of 35°F (1.5°C). In connection with measuring the area temperature heating of the sensor is turned off for 90 minutes at a time. This is done in order to obtain a correct measurement of area temperature which is not influenced by sensor temperature. If a system only has one sensor this sensor is constantly heated for 90 minutes and then turned off for 90 minutes. This entails that measurement of temperature can be up to 3 hours delayed. With more than one sensor this performance is significantly improved.

Security and energy consumption

High security – higher energy consumption

If a high degree of security against ice and snow is wanted, make the following adjustments of the operation parameters:

- Increase the standby temperature
- Increase the melting temperature
- Decrease the moisture level (close to setting 5)
- Prolong the post-heat period

This will give a high degree of security in even dry areas.

Low security – lower energy consumption

Conversely, low energy consumption and a moderate level of security against ice and snow could be prioritized. In this case make the following adjustments of the operation parameters:

- Decrease the standby temperature
- Decrease the melting temperature
- Increase the moisture level
- Shorten the post-heat period

This will give relatively low energy consumption, but the area may remain wet and icy in short periods.



The factory settings are average values providing a relatively high degree of security and moderate energy consumption.

Sensor cable extension

Ground system	1 pcs. PSU 24V dc. 24W		2 pcs. PSU 24V, 24W in parallel	
Number of sensors:	1 or 2		3	4
Cable type	Max. length (m)	Max. length (m)	Max. length (m)	Max. length (m)
1 mm ²	985' (300)	492' (150 m)	262' (80 m)	
1,5 mm ²	1476' (450)	738' (225 m)	394' (120 m)	
2,5 mm ²	2460' (750)	1247' (380 m)	656' (200 m)	
4 mm ²	3940' (1200)	1969' (600 m)	1017' (310 m)	

Roof system	1 pcs. PSU 24V dc. 24W		2 pcs. PSU 24V, 24W in parallel	
Number of sensors:	1	2	3	4
Cable type	Max. length (m)	Max. length (m)	Max. length (m)	Max. length (m)
1 mm ²	1312' (400 m)	328' (100 m)	427' (130 m)	246' (75 m)
1,5 mm ²	1969' (600 m)	492' (150 m)	656' (200 m)	360' (110 m)
2,5 mm ²	3281' (1000 m)	820' (250 m)	1083' (330 m)	623' (190 m)
4 mm ²	5249' (1600 m)	1312' (400 m)	1722' (525 m)	984' (300 m)

The Danfoss Warranty

GENERAL CONDITIONS FOR SALE AND WARRANTY

The acceptance of the order confirmation by the purchaser includes the acceptance of our "General Conditions of Sale and Warranty" as the only ruling condition. No modification of these conditions will be recognized by Danfoss. Any express or implied condition, statement or warranty, statutory or otherwise - not stated herein is excluded.

1. INCOTERMS

The international rules for the interpretation of trade terms "Incoterms" shall apply to the commercial terms used herein.

2. CONFIRMATION OF ORDER

Danfoss shall not be deemed to have accepted an order until written confirmation of the order from Danfoss is dispatched to the prospective purchaser. Quotations, pro forma invoices and the like, shall be subject to confirmation by Danfoss.

3. TERMS OF DELIVERY

At Danfoss' option, the goods can be delivered from any of the Danfoss factories, subsidiaries, or affiliated companies in or outside Canada. Failing special instructions, the goods will be dispatched in the way which Danfoss deems best without guaranteeing this to be the cheapest way of transport.

4. PRICE REGULATIONS

Danfoss reserves the right to adjust accepted prices in the event of alterations in rates of exchange, variations in costs of materials, changes in wages, interference on the part of the Government or similar conditions over which Danfoss has no control.

5. PACKING

Disposable packing is included in the price and will not be credited if returned. Reusable packing is not included in the price and shall be returned in accordance with Danfoss' instructions at purchaser's expense.

6. RISK

From the moment of delivery the purchaser shall bear all risks for the goods, and Danfoss shall not be responsible for loss and damage incurred during the transportation. If so desired by the purchaser, Danfoss will at the cost of and on behalf of the purchaser, effect marine Insurance in English all risk conditions from warehouse to warehouse, at the c.i.f. value of the goods plus 10% and, likewise, Danfoss will effect war risk insurance.

7. TERMS OF PAYMENT

Where payment is not received when due, an interest rate of 10% per annum over and above the actual total back charge will be payable. This rate of interest will also be used in cases where an extension of the period of credit has been granted. The purchaser shall not be allowed to retain payments, or to settle debts by setting off same against possible counterclaims, disputed by Danfoss, or to reduce the invoiced price.

8. TRANSFER OF OWNERSHIP

Until full payment for the goods has been received by Danfoss, the goods shall remain the property of Danfoss and shall not be pawned or pledged in any way.

9. TIME OF DELIVERY

Time of delivery is stated approximately. Danfoss shall not be liable for any delay due to causes beyond Danfoss' control, including

but not restricted to strikes, lockouts, labour disturbances or the like, or in consequence of extraordinary measures on the part of government, hindrances to transportation including ice or other transport difficulties, delayed, incomplete or defective delivery of material ordered in due time from sub-suppliers, failing supply of electricity and similar obstacles to production, fire or workshop accidents at own factories or at sub-suppliers.

10. INFORMATION

The information and technical data contained in catalogues, leaflets and other written material constitutes an approximate guide only. No responsibility for errors or wrong interpretation can be placed on Danfoss. The purchaser cannot claim any rights based on this material. Such reservation shall also apply to suggestions, advice and other services rendered to customers, including installation and servicing instruction for the product delivered.

11. ALTERATIONS

Danfoss reserves the right to make alterations to their products without notice, also to products already placed on order.

12. WARRANTY

Provided that the terms of payment are observed, the purchaser is offered a warranty of two (2) years on thermostats, PX, and RX Kits, ten (10) years on mats and cables. The period of warranty is running from the date stamped on the product. The warranty covers faulty manufacture, design and/or defective materials. The warranty shall cease to be valid if the product is repaired or altered without the consent of Danfoss, applied for purposes for which it is not designed or installed and applied contrary to the instructions given by Danfoss. Expenses in connection with dismantling and mounting shall not be paid by Danfoss. If defects occur while under warranty, the product shall be forwarded to Danfoss, insurance and freight paid. A description of the reason for returning the product shall be enclosed. Products returned shall be free of extraneous equipment. Products repaired under warranty will be returned to the purchaser, freight paid by Danfoss. Parts which have been replaced shall be the property of Danfoss. Any other liabilities are not accepted. Guarantee for products not of Danfoss' own manufacture is only given to the same extent as given to Danfoss, however, not exceeding the normal Danfoss warranty.

13. SECONDARY DAMAGES

Danfoss shall not be held responsible for any indirect or consequential damage e.g. damages to person or property, consequential loss, including loss of production, loss of profit, loss on goods in store or the like, which might arise out of defects and/or delay in delivery of the products sold, irrespective of the cause, including faulty manufacture, design of material.

14. NOTICE OF CLAIMS

Any claim or complaint as to defects and/or delay in delivery of the products shall be submitted in writing by the purchaser to Danfoss immediately.

Guarantee Certificate

The Danfoss Guarantee is granted to:

Name:

Address:

Postal code:

Phone:

Important!

In order to obtain the Danfoss Guarantee, the following must be carefully filled in. See other conditions on previous page.

Electrical Installation by:

Installation date:

Type of thermostat:

Production code:

Supplier information

Danfoss Heating North America
6711 Mississauga Road, Suite 410
Mississauga, Ontario, L5N 2W3
Phone 866-676-8062
Fax 905-285-2056

°F/°C

