

AXPC100-EGPC Pipe Mounted Option

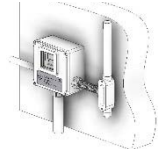

EGPC Wall Mounted Option

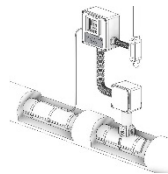

EGPC Stand-Alone Option

DESCRIPTION

The EGPC/AXPC100-EGPC is an electronic temperature controller with 30-mA ground-fault protection. It is ideal for all heat tracing applications requiring accurate temperature monitoring. The controller can be programmed to maintain temperatures up to 215°C (419°F) at voltages from 100 to 277 V and can switch current up to 30 Amperes for the EGPC or 25 Amperes for the AXPC100-EGPC. The EGPC/AXPC100-EGPC is complete with a temperature sensor and is housed in a NEMA 4X rated enclosure. The controller features an AC/DC dry alarm contact relay for monitoring critical applications such as fire protection piping.

These instructions are to be used together with the installation and maintenance instructions for any heating cable or power connection kits utilized with this controller.

EGPC CONTROLLER CONTENTS

QTY	ITEM	DESCRIPTION
1	1	LID
1	2	WIRE COVER
1	3	BOX WITH ELECTRONICS

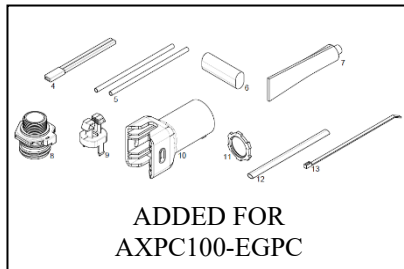
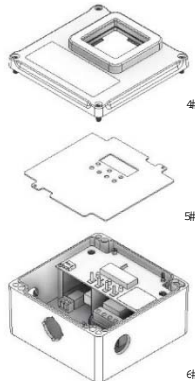

AXPC100-EGPC KIT CONTENTS

QTY	ITEM	DESCRIPTION
1	1	LID
1	2	WIRE COVER
1	3	BOX WITH ELECTRONICS
1	4	TERMINATION PWR LONG SILICONE
2	5	GUIDE TUBE
1	6	SEAL END
1	7	TUBE OF SILICONE
1	8	1" NPT ADAPTER
1	9	CABLE RETAINER
1	10	STANDOFF
1	11	LOCK NUT
1	12	3/8" SHRINK TUBE
1	13	CABLE TIE

OPTIONAL INSTALLATION MATERIAL

- Pipe Clamp – PC03, PC12 or PC20 (included)
- Fiberglass Tape – GT6 or GT60
- HC-SPA Small Pipe Adapter – For 1.0"
- EHRTD7 (RTD: PT100, 3 wire)

RECOMMENDED TOOLS

- Large Cross Blade (Philips) Screwdriver
- Small Cross Blade (Philips) Screwdriver
- Wire Cutters
- Adjustable Wrench (52mm [2.1"] size)
- Needle Nose Pliers
- Large Slotted Screwdriver

WALL MOUNTING THE EGPC/AXPC100-EGPC

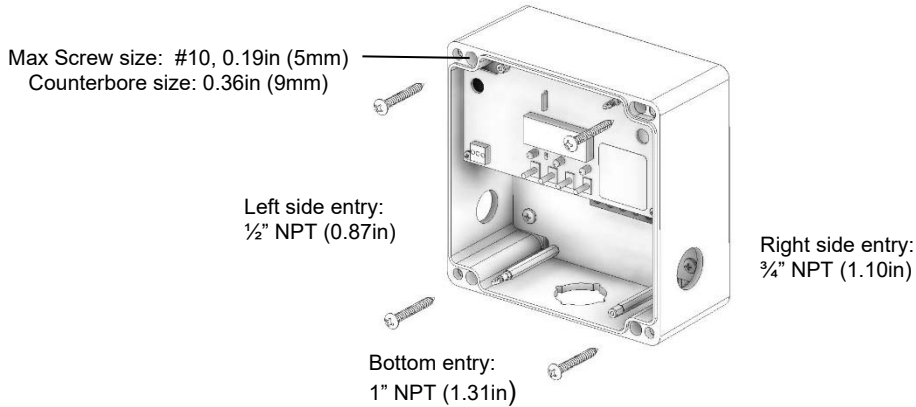

- Attach Enclosure to wall using appropriate mounting

CONNECTING HEATING CABLE DIRECTLY TO EGPC/AXPC100-EGPC

- Remove the lid and wire cover.
- Bring the power cable from the heater into the controller, and terminate the two power cables each into one of the terminals marked Output. Terminate the ground wire or braid into the ground terminal.
- This kit is designed for use with all wattages of SR-J, TSR-J, TSR-F and HSR-F heater cables
- To directly connect MI cable you must use a 1 to 3/4" reducing bushing with grounding hub.

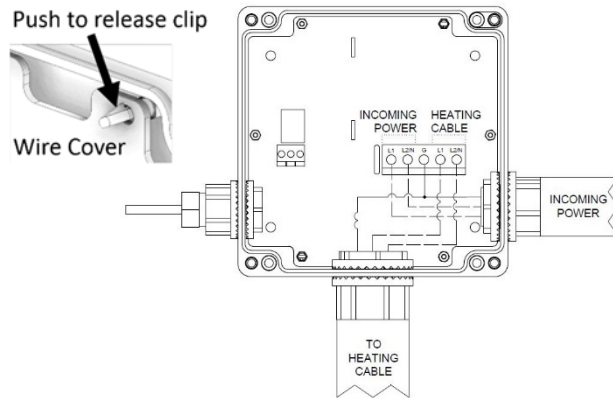

CONNECTING HEATING CABLE WITH A POWER CONNECTION KIT

- Remove the lid and wire cover.
- Terminate the heating cable power wires in the power connection kit as per the instructions that come with the kit
- Run the two power output wires of the power connection kit into the "OUTPUT" terminals in the controller.
- Connect the ground hub of the power connection kit to the ground terminal in the Controller.
- Incoming power should be connected likewise into the Input terminals

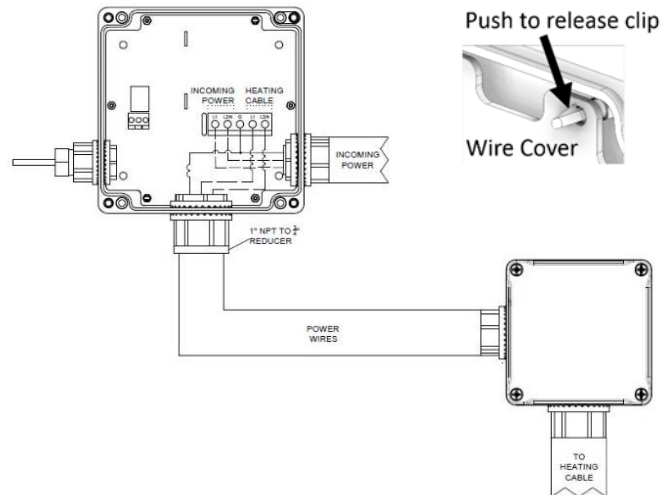

AXPC100-EGPC STANDOFF INSTALLATION

STEP 1

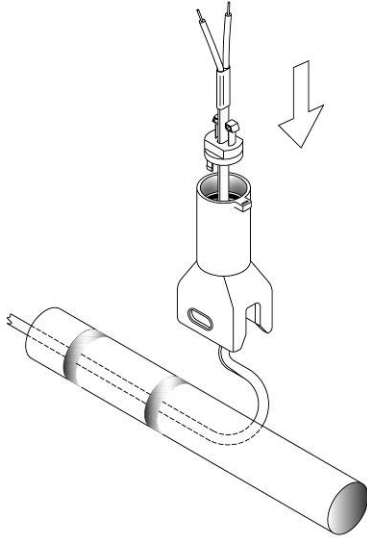

- Pull excess heating cable back through standoff.

STEP 2

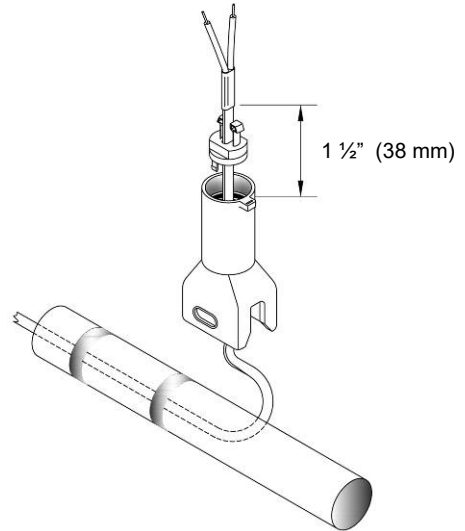

- Allow 1 1/2" (3.81 cm) of heating cable to remain above top of standoff body.

STEP 3

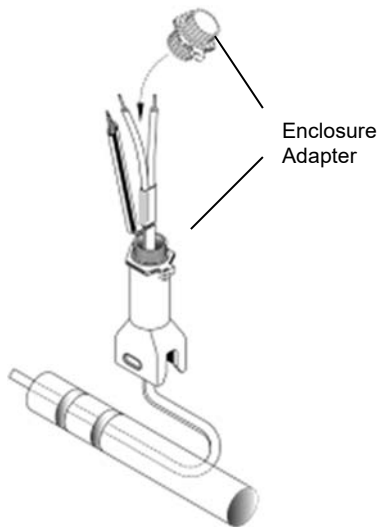

- Carefully slide enclosure adapter over cable terminations.
- Screw enclosure adapter into standoff until fully seated at positive stop.

STEP 4

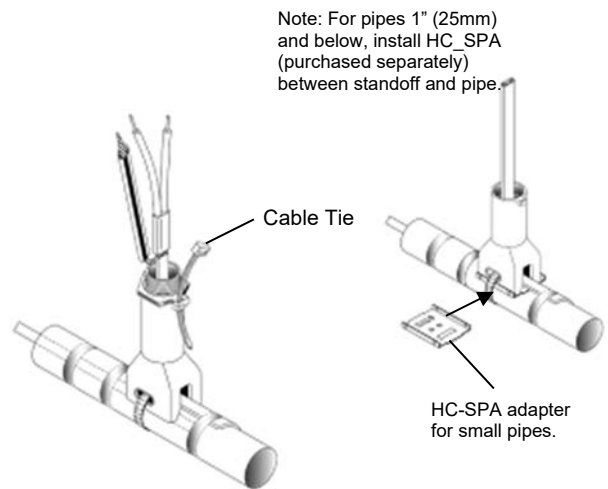

- Mount standoff securely to pipe.
- Insert supplied cable tie through slot provided to prevent possible rotation of enclosure.

STEP 5

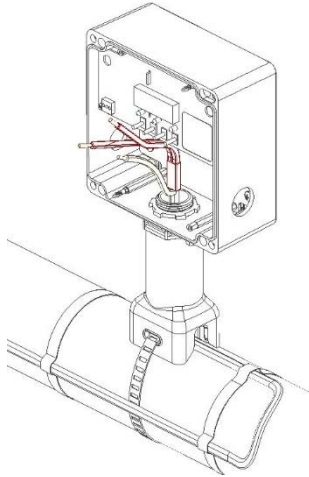

- Install enclosure and secure to enclosure adapter with supplied locknut.
- Do not over tighten locknut
- Enclosure may be rotated in 90° increments to match installation requirements.

STEP 6

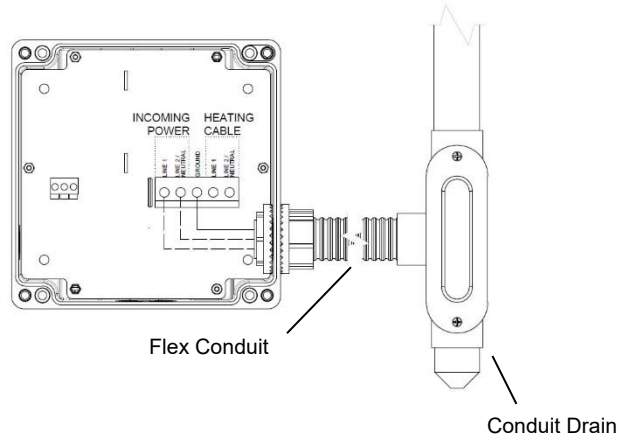

- Install flex conduit and drain as shown.
- Terminate power and ground wires to terminal block.
- Install enclosure cover.

STEP 7



WARNING

- **Potential High Temperature – Ensure proper selection of power cable**

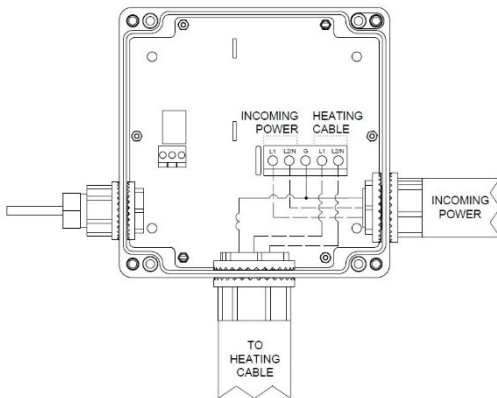

- Heating cable installations require incoming power wiring to be rated for 105°C operation.
- Maximum steady-state current may not exceed 18 amps, 25 amps for XLT cable.
- Verify that all connections are properly installed and secure.

STEP 8

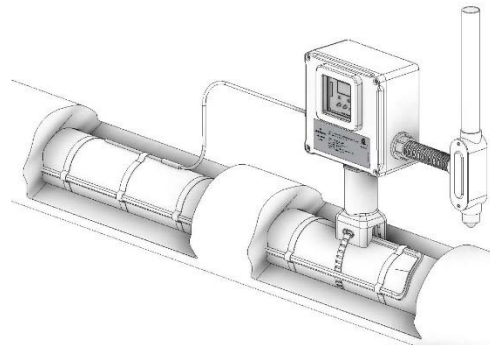

- Install thermal insulation and protective lagging.
- Apply sealant around standoff penetration to prevent moisture entry.
- Leave installation instructions with end user for future maintenance and/or trouble shooting.
- Fill in the blank fields on the label located on the cover of the junction box as follows:
CIR. NO. – Electrical circuit heating cable connected to.
CAT. NO. – Type of heating cable used
VOLTS – Operating voltage of heating cable – Max 277VAC
AMPS – Operating current of heating cable – Max 30A

CONNECTING INCOMING POWER

- Install conduit, fittings, and wires according to local standards
- Wire size limits: 18 AWG – 6 AWG (See installation and operation manual for self-regulating pipe tracing heater cable for further detail (14030-001)).
- In order to minimize loosening due to pipe vibration, use flexible conduit
- Pull in power and ground wires, strip off ½”(13mm) of insulation and terminate as shown.

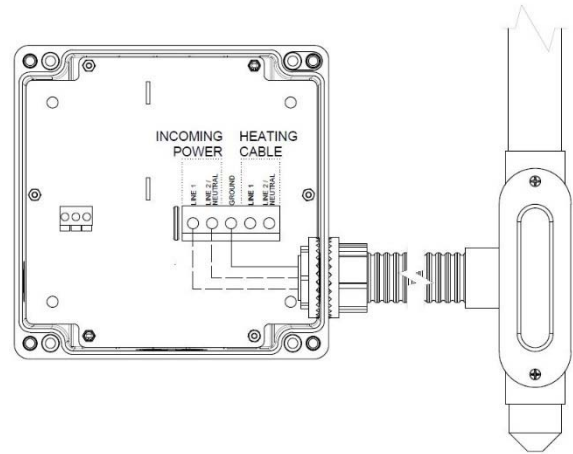

CONNECTING TEMPERATURE SENSOR

- This unit can be used with any 100Ω, platinum, 3-wire RTDs
- Adjust the length of the temperature sensor to meet the application needs Strip the 1/3 ” (9mm) insulation and either connect an red ferrule (18AWG) or tin the end.
- Insert the wires into the terminal block on the plate above as shown.
- Wire size must be within AWG 18-24

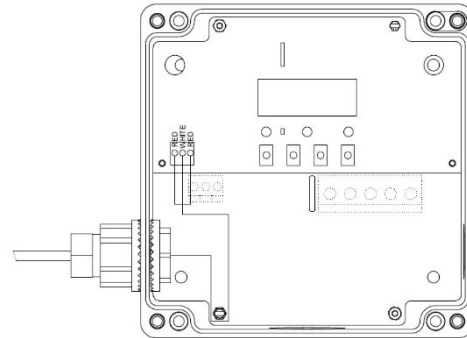

CONNECTING ALARM WIRING

- The controller has a dry form C contact Max.2A 20-277VAC, 12-48VDC
- Connect the alarm wires as shown to either the NO and C terminals (for normally open) or NC and C terminals (for normally closed)

Condition	N/O	N/C
Power Off	OPEN	CLOSED
Power On	OPEN	CLOSED
Alarm	CLOSED	OPEN

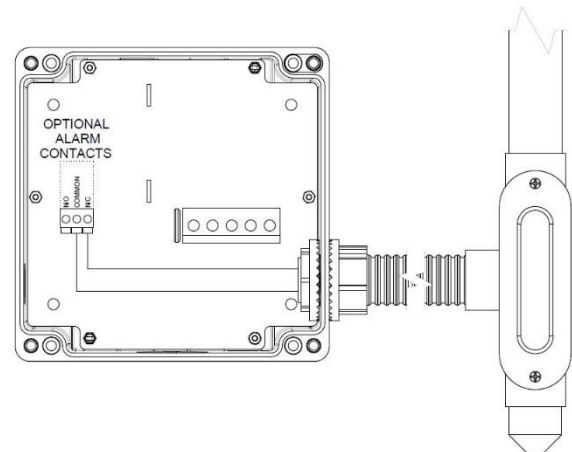

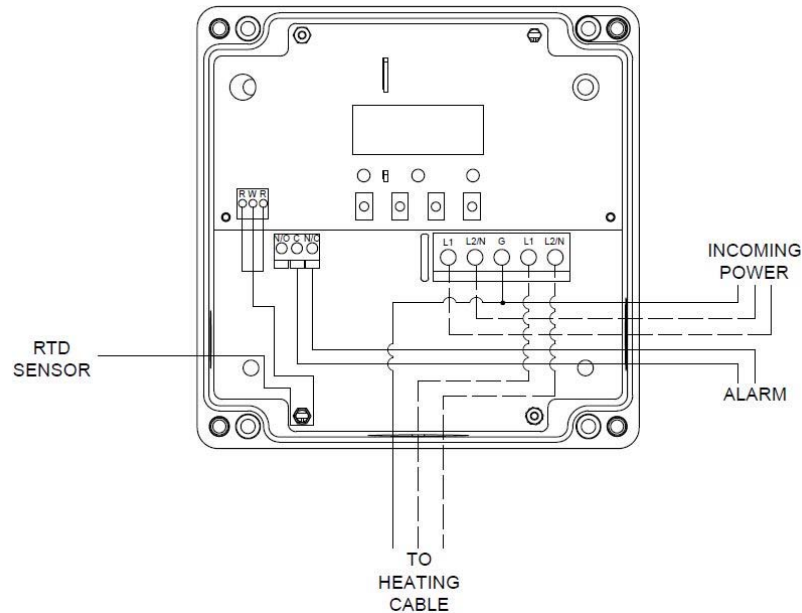
WIRING VERIFICATION**FINISHING INSTALLATION**

- Install wire cover by attaching it to the plastic standoffs, and ensuring that it snaps in place.
- Program the Controller, see MENU SETTINGS section for details.
- Attach the lid with the included screws
- Leave these instructions with the end user for future reference.

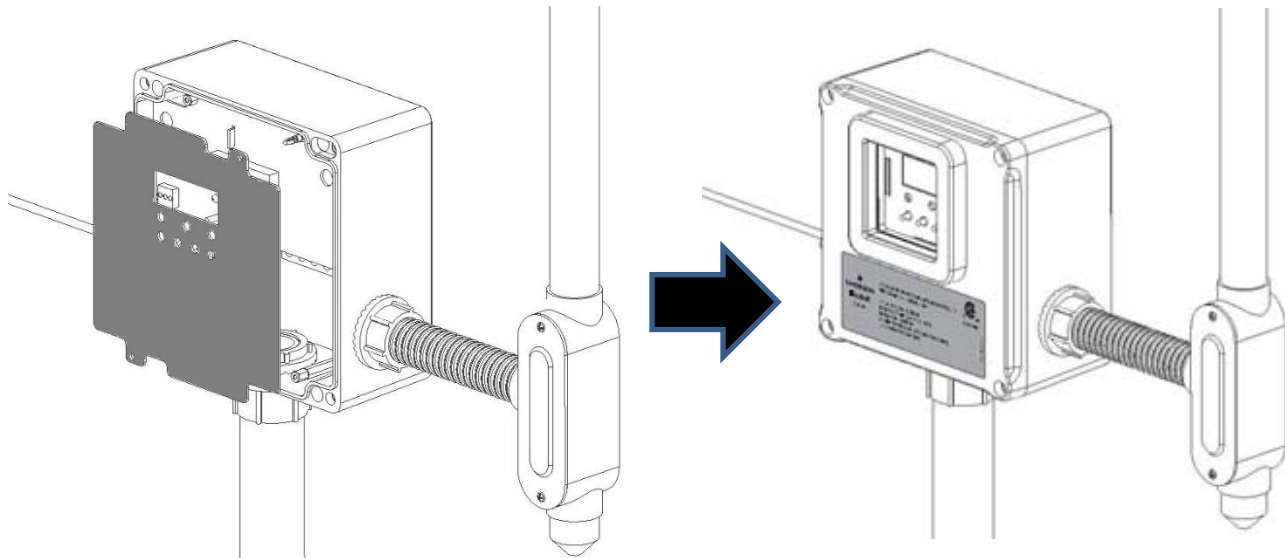

MENU SETTINGS

The following chart:

- Shows how the items will appear on the Controller
- Lists the parameters in order of appearance on the Controller.
- Lists the default, min. and max values for each parameter.

Menu Items	Parameter	Default	Min	Max
Unit	Units (°C or °F)	Celsius	-	-
StP	Maintain Setpoint	4°C (40°F)	0°C (32°F)	218°C (425°F)
dbd	Deadband	3°C (5°F)	1°C (2°F)	6°C (10°F)
HI ALr	High Alarm Setpoint	Off	Setpoint + deadband + 3°C (5°F)	223°C (433°F)
Lo ALr	Low Alarm Setpoint	Off	-9°C (16°F)	Setpoint - deadband - 3°C (5°F)

Programing the Controller:

- To enter Settings mode, Press the “MENU” button for 3 seconds and the display will flash “Unit” for 1 second and then C or F depending on current settings.
- To change the setting press “UP” or “DOWN” to reach the desired value.
- To save and move to the next setting press “NEXT”
- Pressing “NEXT” on “Lo ALr” saves and returns to normal mode.
- To save and return to normal mode at any point of the menu; hold “MENU” for 3 seconds until the actual temperature is displayed.

EGPC/AXPC100-EGPC LEDs

The controller contains 3 LED lights which are viewable through the enclosure window
These lights are as follows:

- **ACTUAL (Amber):**
Indicates the status of the Actual Temperature as detected by the RTD.
Blinking: The Actual temperature is below setpoint and the heater is energized.
Solid: The Actual temperature is at or above the set point, the heater is de-energized.
- **SETPOINT (Amber):**
Indicates that value on the display is the setpoint temperature value
- **ALARM (Red):**
Blinks when an Alarm condition is present.
For alarm details see section “EGPC/AXPC100-EGPC Error Displays”.



ERROR DISPLAYS

The Controller will display the following upon detecting an error state:

- Low Temperature Alarm**
When Actual temperature(AT) is less than or equal to the low temperature alarm value (LTAV), Alarm LED (Red) will start flashing and the display will flash as follows: “Lo”, “ALr”, “LtSp”, LTAV, “Act”, AT
- High Temperature Alarm**
When AT is greater than or equal to the high temperature alarm value (HTAV) Alarm LED (Red) will start flashing and the display will flash as follows: “HI”, “ALr”, “HtSp”, HTAV, “Act”, AT
- Temperature Sensor Alarm**
When the RTD is shorted or open, the Alarm LED (Red) will start flashing and the display will start flashing “Err”, “SnSr” alternatively.
- Ground Fault Trip**
When ground fault current is greater than 30mA the Alarm LED will start flashing, and the display will start flashing “GF”, “triP” alternatively, and the output relay will be deactivated until the fault is cleared and the GF is reset.

ALARM STATUS & TESTING	
Lo ALr LtSp ### Act ###	Low Temp Alarm
HI ALr HtSp ### Act ###	High Temp Alarm
Err SnSr	RTD Alarm
GF triP	Ground Fault Trip
To Test Ground Fault: Press NEXT for 3 sec	
GF triP	Pass
FAIL	Fail
To Reset Ground Fault After Test: Press DOWN for 3 sec	

GROUND FAULT TESTING

To Initiate Ground Fault Testing:

- Press “NEXT” button for 3 seconds
- The Output relay will be energized (if not already) and artificial leakage current of 40 mA will be induced
- The Output relay should be deenergized and the display should flash “GF”, “triP” alternating and the Alarm should be activated.
- If the Output relay does not trip, “FAIL” will flash on the display and the Output relay will be forced off.
- To reset the Controller, press and hold the “DOWN” button for 3 seconds.

GENERAL CONDITIONS OF SAFE USE

- To prevent electrical arcing and fire hazard, all cable connections and electrical wiring connections should be sealed against moisture. This includes the use of proper cable sealing kits and the moisture proofing of all wire connections.
- The metal sheath/braid of the heating cable must be connected to a suitable ground path before electrical power is connected to this equipment.
- Isolate electrical power supply before opening or removing the Wire Cover.
- The enclosure cover must be secured with all screws provided to maintain the environmental ratings.
- The main components used in this connection system may present a hazard from static electricity. Only surface cleaning with a damp cloth is acceptable.
- Routine maintenance is required to maintain compliance with health and safety legislation:
 - Check that the cover gasket is in place and not damaged each time the enclosure is closed.
 - Check that all cover screws are in place and secure each time the enclosure is closed.
 - Check the security of all cable entries on a routine basis.
 - Check that all electrical connections are tight and secure on a routine basis.
 - Check for physical damage and replace as required.
- This connection system is designed for use in areas subject to normal industrial levels of vibration. They are not designed for use in areas subject to intentional or extreme conditions of vibration.

APPROVALS

NEC®; NFPA 70: National Electrical Code®, International Electrical Code Series



CLASS - C481382 - TEMPERATURE-INDICATING AND REGULATING EQUIPMENT
Other than Appliance Type - Certified to US Standards
CLASS - C481302 - TEMPERATURE-INDICATING AND REGULATING EQUIPMENT
Other Than Appliance Type
CSA LR 021208

EasyHeat Inc. products are supplied with a limited warranty. Complete Terms and Conditions may be found on EasyHeat's website at www.EasyHeat.com. EasyHeat is a wholly owned subsidiary of the Appleton Group LLC (Heating Cable Systems), 2 Connecticut South Dr, East Granby, CT, 06026. A division of Emerson Automation Solutions.

