

QUICK-REFERENCE INSTALLATION GUIDE

SNOW SWITCH[®] MODEL PD PRO AUTOMATIC SNOW/ICE MELTING SYSTEM CONTROL PANEL

PACKING LIST

QTY.	PART NO.	DESCRIPTION
1	23736	PD Pro
1	23731	Accessory Kit
1	24455	PD Pro Installation Sheet (this document)
1	23735	PD Pro Instruction Manual

NOTE:

The Snow Switch Model PD Pro Automatic Snow and Ice Melting System is permanently connected equipment and does not have an internal disconnect device. A readily accessible disconnect device, short circuit, and current protection shall be provided and are not supplied by ETI. When power is applied, the system will start.

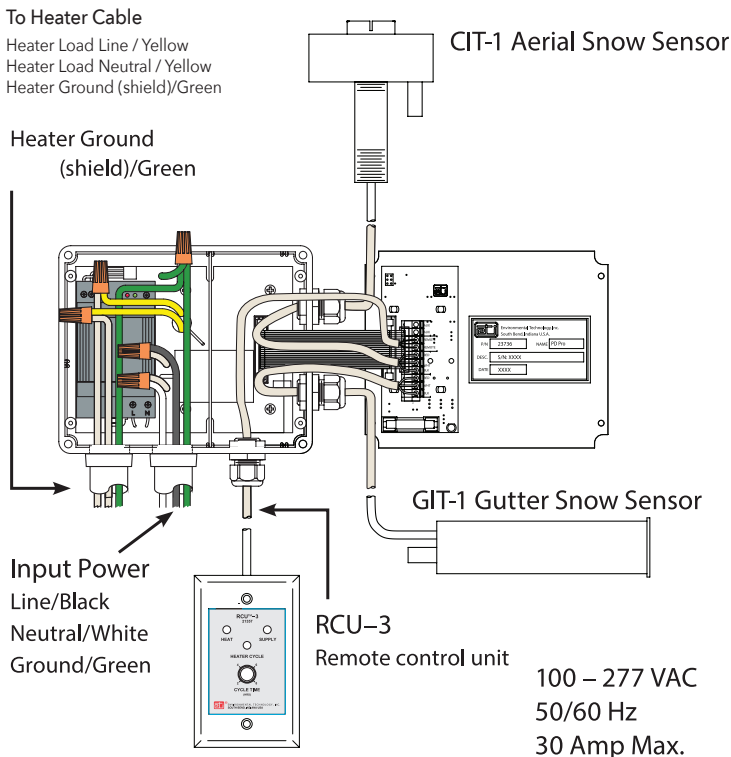

Power Cable (provided by customer)	Size for 30 Amp maximum load
Sensor Wiring	#18 AWG jacketed, 3-conductor
Heater Cable (provided by customer)	Size to system load
Remote Wiring	#22 AWG jacketed, 2-conductor
Temperature Sensor Assembly Wiring	#22 AWG jacketed, 2-conductor

QUICK-REFERENCE INSTALLATION GUIDE

Terminal block J1 with terminals labeled for system cables and wiring

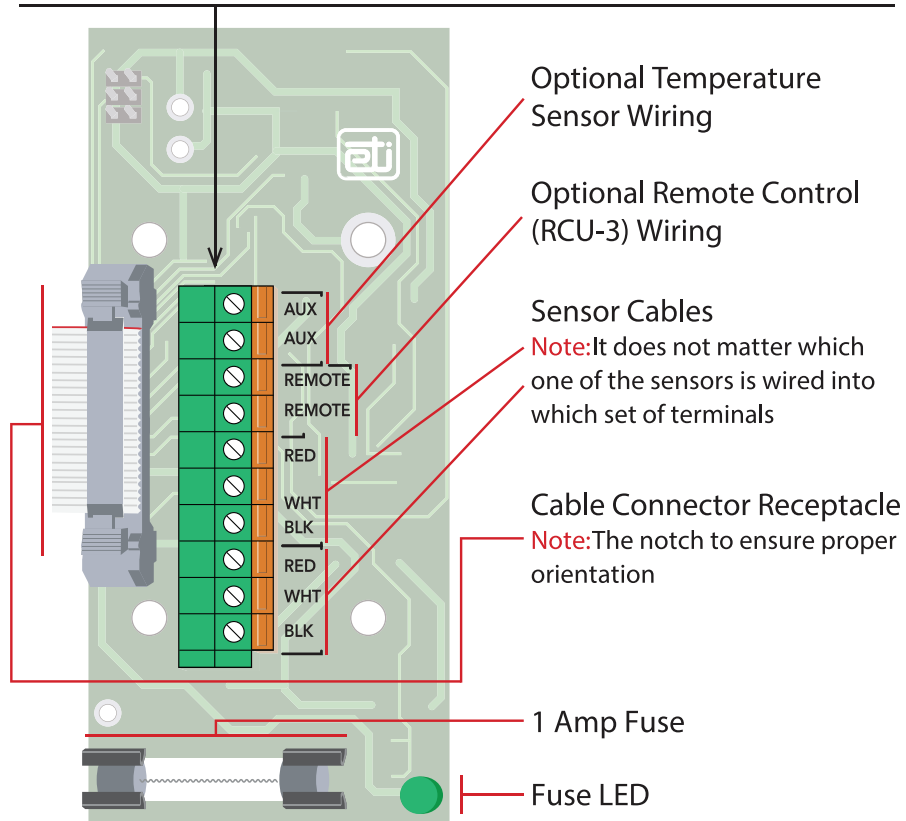

Cable Function	Wire Lead	Connect To:
INPUT POWER (provided by customer)	Line 1 Line 2 / Neutral Ground	Black White Green
OUTPUT TO HEATER (provided by customer)	Heater Load Line Heater Load Neutral Heater ground (Shield)	Yellow Yellow Green

QUICK-REFERENCE INSTALLATION GUIDE

SAFETY & WARNINGS

1. Even when the heat tapes are disconnected, as long as the circuit breaker is on and power is running to the unit, voltage is still being applied to the yellow heat tape leads. Therefore, never touch the ends of the yellow leads or let the two leads touch each other. Do not let the two yellow heat tape leads contact any component inside the unit.
2. Any installation involving electric heater wiring must be grounded to earth to protect against shock and fire hazard. Suitable ground fault detection and interrupting systems must be in use at all times to reduce shock and fire hazard and to protect personnel and equipment.
3. Electric wiring to heating elements must be installed in accordance with National Electrical Code (NEC) requirements, as well as other local and applicable electrical codes and third party standards.
4. Only UL listed, 4X, raintight conduit hubs and cable glands are to be used. The hub is to be connected to the conduit of a rigid conduit system before the hub is connected to the enclosure.
5. Ensure a sealed, watertight installation. Waterproof all cable runs, seal all box joints, and properly terminate wiring.
6. Shut off system circuit breaker prior to beginning installation.

PRIOR TO INSTALLATION

1. Install & service this device only if a qualified electrician trained to perform such work.
2. Refer to page 8 of the PD Pro Instruction Manual to learn about optional equipment available for the PD Pro system which might be of interest to you.
3. Before beginning installation, lay out the system components in their approximate location on the site to help you visualize the system and evaluate exact component and junction box placement, as well as required cable and conduit lengths.

4. It is recommended to read these installation instructions prior to beginning installation.

INSTALLATION

1. Install the control box. Locate and install the control box on a wall using the box itself as a template to determine the mounting hole footprint. Install the box to a solid, stable surface capable of supporting four times the weight of the box, or about 20 pounds. Use all four mounting holes. Install the control box to the wall using heavy-duty mounting hardware long enough to fasten the box securely. Do not fully tighten the mounting hardware at this time. Leave the mounting hardware loose enough to work the conduit into place. Hardware will be fully tightened following installation of the conduit.
2. Once the control box is installed but with the mounting hardware not yet fully tightened, with the circuit breaker off, install the sensor(s) and sensor cables. Refer to the installation instructions provided with each sensor. For greater system flexibility, it is recommended to route the sensor cables through conduit. If installing an extension onto the sensor cable(s), a junction box is required in accordance with applicable codes. Feed the sensor cable through the weather-tight connection ports on the right side of the control box, then connect the leads to the circuit board terminals labeled RED, WHT, and BLK. If using more than one sensor, it does not matter which sensor goes to which set of terminals.
3. With the circuit breaker off, install the heat tape (heater cables). Install the heat tape in accordance with National Electrical Code (NEC) and heat tape manufacturer's specifications and requirements, as well as other local and applicable building and electrical codes and standards. If using a SIT-6E pavement-mounted sensor, run the heat tape so it doesn't touch the SIT-6E cable. Refer to the schematic diagram on this Installation Sheet. Route the heat tape through conduit as directed by the heat tape

QUICK-REFERENCE INSTALLATION GUIDE

manufacturer, then connect the heat tape leads to the two yellow wires inside the control box. The Heater Load and Heater Load 2 yellow wires are interchangeable; it doesn't matter which heat tape lead goes to which of the yellow wires.

4. As applicable, install optional device(s) and associated cable(s). Refer to the schematic. Route the cable(s) through conduit and into the control box as shown, then connect the temperature sensor leads to the circuit board terminals labeled AUX and the remote control leads to the terminals labeled Remote.
5. With the circuit breaker off, install the power cable. As shown in the wiring charts, the power cable is provided by the customer. Size the cable for a 30 Amp maximum load. Run the cable through conduit and connect the leads to the control box wiring. The line is black, neutral is white, and ground is green. The PD Pro has no power switch so remember that power is running to the system as soon as power is applied.
6. With cabling routed through conduit, install the conduit runs to the control box. Once conduit is secure, fully tighten the control box mounting hardware and re-assemble control box panels and cover in their original location.
7. At this time, turn the system circuit breaker back on. The green SUPPLY LED light should be on and will always be on while power is running to the control.
8. As directed on page 17 of the PD Pro Instruction Manual, perform Post-Installation Testing as described, depending which sensors are used in your system. It is important to perform this testing prior to operating the system.
9. Once all system components have been properly installed and tested, the circuit breaker has been turned on, and power is running to the control box, the system is operational. Now, rotate the Hold-On Time control knob on the face of the control box to set the desired duration of the heating cycles which will begin automatically as described in the Instruction Manual, or manually by pressing the Heater Cycle button, and will run for the length of time set, or until the Heater Cycle button is pressed.

Heating Cable

Note: ETI recommends using a CIT-1 in conjunction with either a SIT-6E for pavement melting or a GIT-1 for gutter and roof melting.

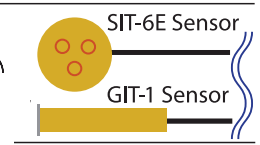

CONTACTING CUSTOMER SERVICE

For technical help, questions or comments concerning this product or any ETI product contact Customer Service 8:00 a.m. - 5:00 p.m. EST.

Email: info@networketi.com

Web: networketi.com

Mail: ETI
1850 North Sheridan Street
South Bend, IN 46628

LIMITED WARRANTY

ETI's two year limited warranty covering defects in workmanship and materials applies. Contact Customer Service for complete warranty information.

DISCLAIMER

ETI makes no representations or warranties, either expressed or implied, with respect to the contents of this publication or the products that it describes, and specifically disclaims any implied warranties of merchantability or fitness for any particular purpose. ETI reserves the right to revise this publication, and to make changes and improvements to the products described in this publication, without the obligation of ETI to notify any person or organization of such revisions, changes or improvements.