

SNOW SWITCH® MODEL GIT-1

AUTOMATIC SNOW/ICE MELTING SYSTEM CONTROL PANEL

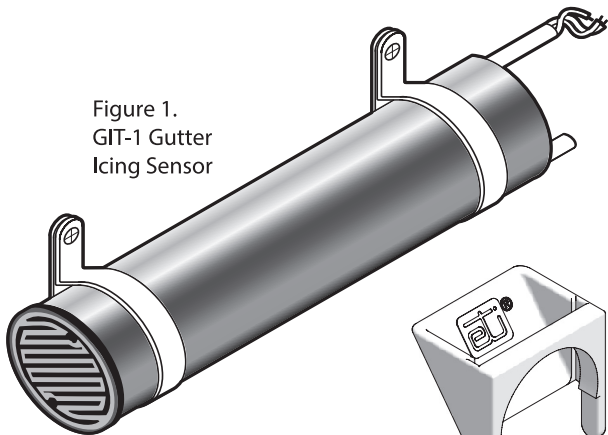

Figure 1.
GIT-1 Gutter
Icing Sensor

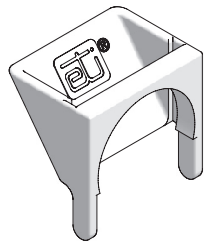

Figure 2. Optional
Moisture Sensor Cup



Figure 3.
Moisture
Sensing Grid

PACKING LIST

17816 Installation Sheet (this document)
11351 GIT-1 Gutter Deicing Sensor and Clamps
23864 Moisture Sensor Cup

GUTTERS

1. Where it will detect initial snow and ice, position or lay sensor within 1/4"(6.4mm) of the gutter bottom. For applications not using the optional Moisture Sensor Cup (Figure 2; see its manual, p/n 23973), ensure moisture sensing grid (Figure 3) faces downstream (ambient air temperature sensor facing upstream) to avoid collecting debris against the grid. Avoid locations where puddling may occur. Sensor may be fastened to the fascia with the included mounting clamps, using #8 or #10 screws or bolts and standoffs as required (not furnished).

DOWNSPOUTS

2. Sensor may be mounted in downspout or on roof edges, positioned to ensure snow sensing. However, be certain to protect it from falling or shifting snow and ice masses. Fold cable back parallel to sensor body and secure with mounting clamps (or weatherproof tape). Suspend sensor in downspout with moisture sensing grid facing up (ambient temperature sensor facing down) as close to the downspout opening as possible.
3. Up to six (6) GIT-1 sensors may be wired in parallel to one control panel; any sensor will activate deicing. System will remain activated until ALL sensors are clear of ice, snow and water.
4. Debris collected against the sensor grid will degrade sensor performance. Locate sensor to avoid falling and blowing debris. Clean gutters before winter season to assure best operation.
5. To prevent corrosion during off-season months, maintain the power to the sensor to allow evaporation of moisture from the sensing grid.

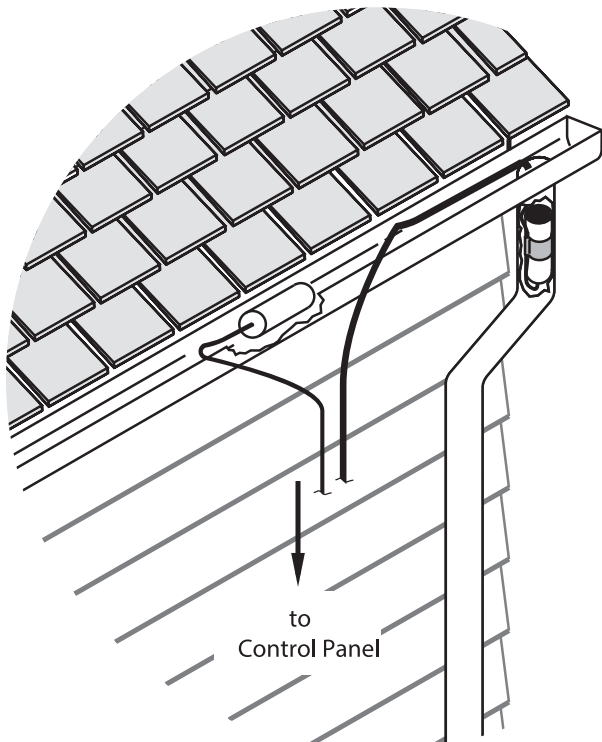
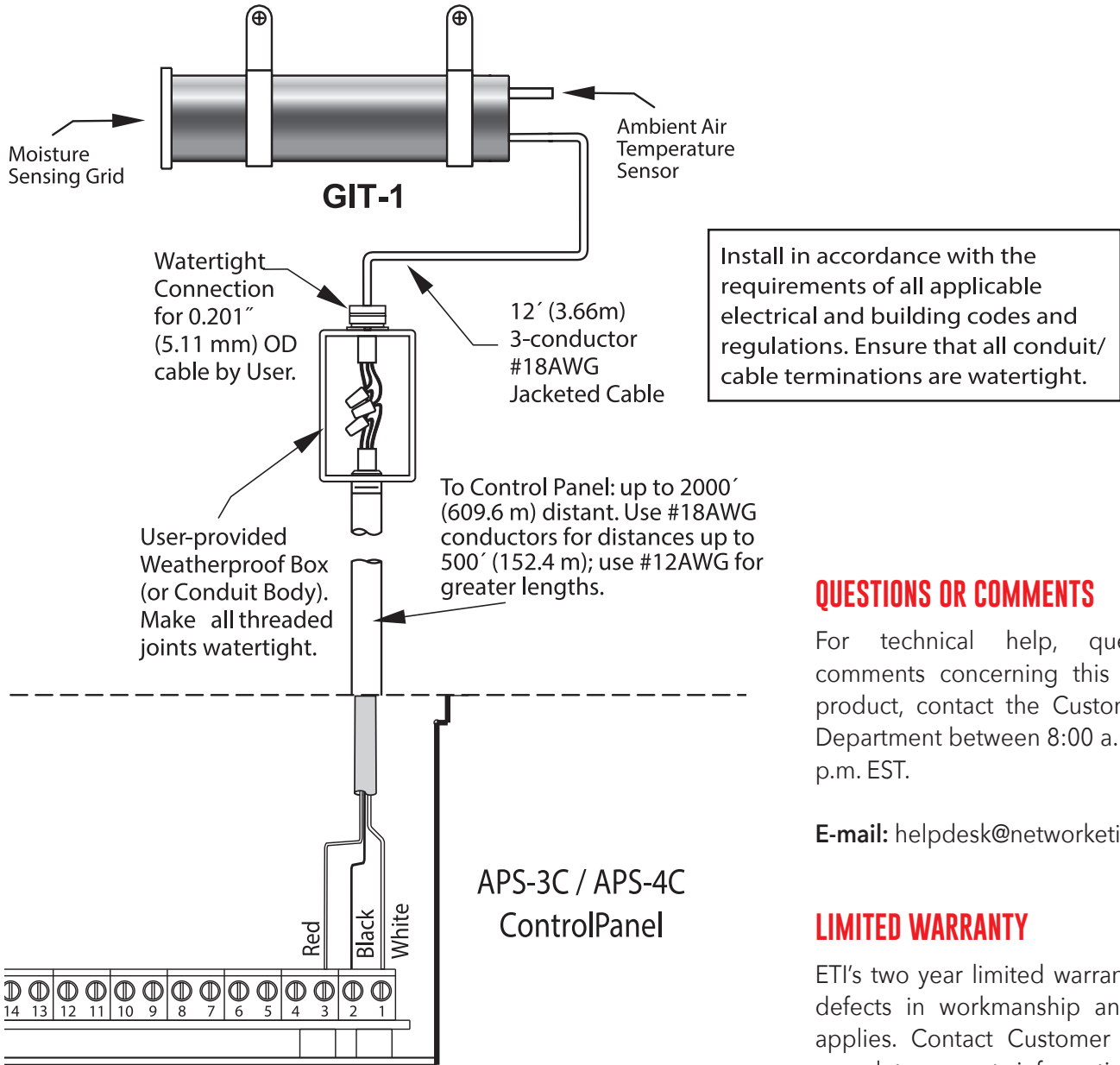

Figure 4. GIT-1 Wiring Diagram.



QUESTIONS OR COMMENTS

For technical help, questions or comments concerning this or any ETI product, contact the Customer Service Department between 8:00 a.m. and 5:00 p.m. EST.

E-mail: helpdesk@networketi.com

LIMITED WARRANTY

ETI's two year limited warranty covering defects in workmanship and materials applies. Contact Customer Service for complete warranty information.

DISCLAIMER

ETI makes no representations or warranties, either expressed or implied, with respect to the contents of this publication or the products that it describes, and specifically disclaims any implied warranties of merchantability or fitness for any particular purpose. ETI reserves the right to revise this publication, and to make changes and improvements to the products described in this publication, without the obligation of ETI to notify any person or organization of such revisions, changes or improvements.