

Chromalox[®]

2110 Temperature Controller

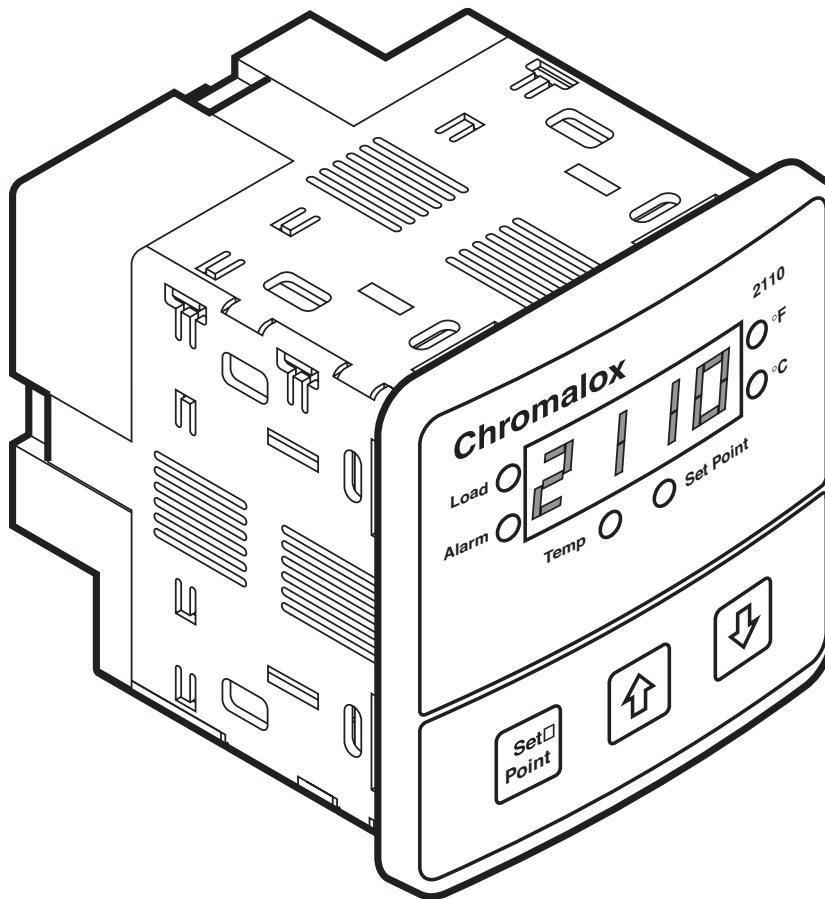

User Manual

0037-75409
PK498-1
May, 2012



Table of Contents

Manual Sections

1–Quick Setup	1
2–Introduction	2
3–Installation and Wiring	4
4–Adjusting Setpoint and Configuration	12
5–Controller and Alarm Operation.....	16
6–Replacing Output Modules.....	17
7–Calibration	19
8–Specifications	21
9–Troubleshooting	22

Illustrations

1.1 Dip Switch Settings	1
1.2 Establishing the Set Point	1
1.3 Adjusting the Set Point.....	1
2.1 Front Panel Identification	2
2.2 Typical Application	3
2.3 Model Identification.....	3
3.1 Default Dip Switch Settings	4
3.2 Removing Mounting Collars.....	5
3.3 Mounting Dimensions	6
3.4 Mounting the 2110	6
3.5 Wiring Terminal Identification	7
3.6 Thermocouple Connections with Shield	8
3.7 Three-Wire RTD Connections with Shield.....	9
3.8 Two-Wire RTD Connections	9
3.9 Control Output Wiring–R1 and S0.....	10
3.10 Control Output Wiring–R3	10
3.11 Control Output Wiring–V0	10
3.12 Control Output Wiring–S1 and S2.....	11
3.13 90-260 VAC Instrument Power Connections	11
3.14 Alarm Connections.....	11
4.1 Establishing the Set Point	12
4.2 Adjusting the Set Point.....	12
4.3 Configuring 2110.....	13
4.4 Configuring 2110.....	13
4.5 Configuring 2110.....	13
4.6 Configuring 2110.....	13
4.7 Configuring 2110.....	13
4.8 Configuring 2110.....	13
6.1 Replacing Output Module	18

2110 Temperature Controller

Section 1—Quick Setup

After the controller is properly wired into the system, the user only needs to verify the sensor input and control type and adjust the set point.

Setting the Sensor and Control Mode

Adjust the dip switches located on the bottom of the unit as shown in Figure 1.1. The factory settings are J, TC, °F, and PI. It is simpler to adjust the dip switch prior to mounting the 2110.

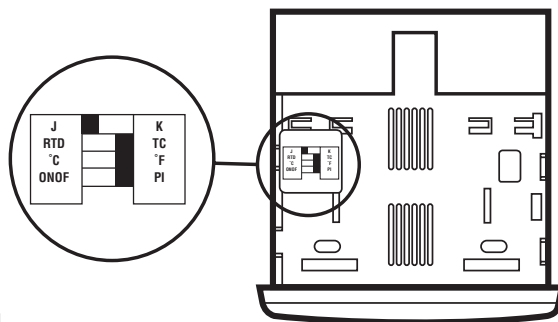

Figure 1.1
Dip Switch Settings

Adjusting the Set Point

1. Apply power to the unit.
2. To adjust the set point on the Chromalox 2110 Temperature Controller, press and hold the Set Point button (see Figure 1.2). The Set Point light is illuminated.
3. While still pressing the Set Point button, press either the \uparrow or \downarrow button to adjust the set point to the desired value (see Figure 1.3). Holding the \uparrow or \downarrow button increases the speed of the set point changes.

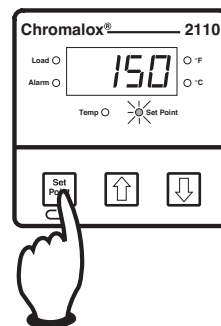

Figure 1.2
Establishing the Set Point

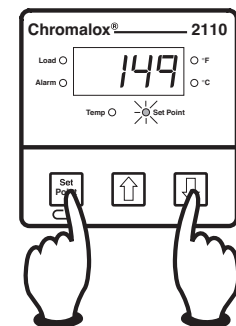

Figure 1.3
Adjusting the Set Point

The Controller is now operational with factory settings. For more precise control, set up of the alarm, etc., see *Section 4 – Adjusting Set Point and Configuration*.

Chromalox[®]

Section 2—Introduction

Description

The Chromalox 2110 Temperature controller offers simple setup, flexibility and control features in an attractive, compact design. The 2110 is housed in a rugged, plastic 1/4 DIN package that only requires four inches behind the mounting surface. Straight-forward operation and easy-to-use control features are major strengths of the 2110 controller.

Easy Three-Step Setup: The 2110 delivers exceptional process temperature control. Your process is up and running after three easy setup steps: 1) Select the sensor and control type, 2) Hook up the system and 3) Select the desired temperature.

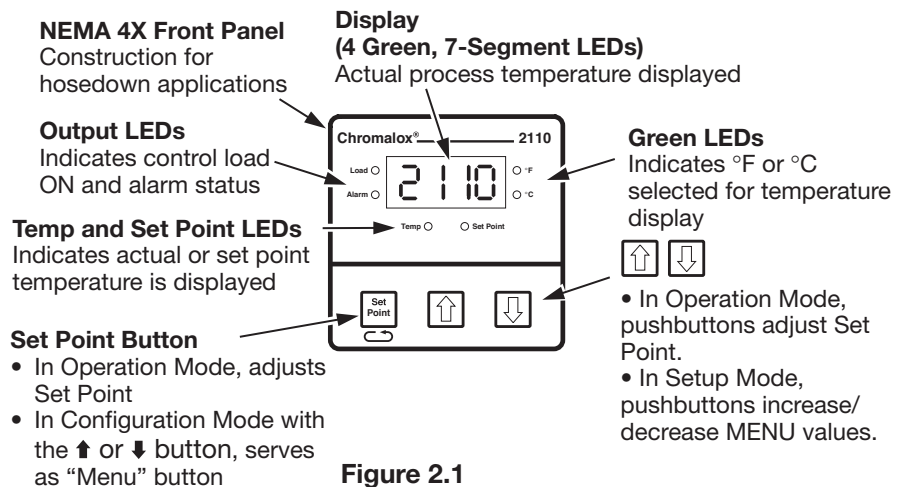

Figure 2.1
Front Panel Identification

Inspection and Unpacking

Your Chromalox 2110 controller should arrive in good condition. Upon arrival, inspect the packaging for any visible damage.

Unpack the controller and carefully inspect for product damage that may have occurred during shipment. If the package or contents have been damaged in shipping, you must file a claim with the delivery service. The delivery service will not accept a claim from the shipper.

If not immediately installing the controller, store in a cool, dry environment in its original protective packaging. Temperature extremes and excessive moisture can damage the instrument.

2110 Temperature Controller

Typical Application

Figure 2.2 shows the 2110 in a typical application.

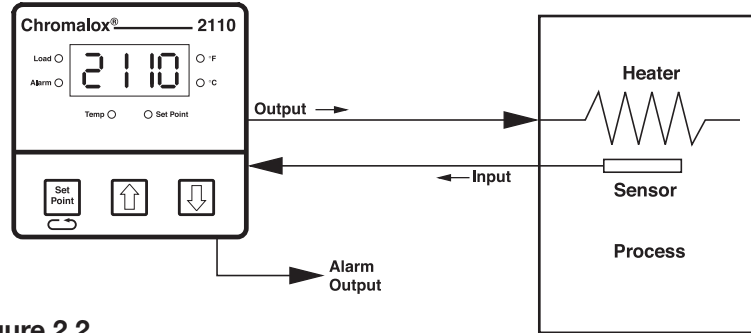

Figure 2.2
Typical Application

Model Identification

Before installation, please identify your controller model number. The model number appears on a label on the side of the housing. Use Figure 2.3 to identify the options in your controller.

Model

2110	1/4 DIN Controller, with Selectable Thermocouple or RTD Inputs					
	Code	Control Output				
	R1	Relay, 1 Amp Form A, 120/240Vac				
	R3	Relay, 20 Amps Form A, 120/240Vac				
	V0	Solid State Relay Drive, 24Vdc @ 40ma				
	S0	Solid State Relay, 1 Amp, up to 240 Vac				
	S1	Solid State Relay, 5 Amps, up to 240Vac				
	S2	Solid State Relay, 10 Amps, up to 240Vac				
		Code	Alarm Output (Kit Option)			
		0	No Alarm			
		1	Alarm Form "C" Relay, 5 Amps at 120Vac, 2.5 Amps at 240Vac			
		Code				
		0	Add to Complete Part Number			
			Code	Power Supply		
			0	90-260Vac		
2110	-	R3	1	0	0	Typical Model Number

Figure 2.3
Model Identification

Chromalox®

Section 3—Installation and Wiring

Sensor and Control Type Selection Switches

Set the Chromalox 2110 controller's configuration via mechanical dip switches, located on the bottom of the unit. Factory settings are J, TC, °F, and PI Control. Switches are easier to set before mounting.

To change the switch settings, first disconnect all wiring and power from the unit. Adjust switch settings as follows:

Switch	Function	Setting Options	Factory Setting
A	Thermocouple	J or K	J
B	Input Type	TC or RTD	TC
C	Temperature Units	°F or °C	°F
D	Control Type	ON-OFF or PI	PI

If input type is thermocouple, switch A selects either thermocouple type **J** or **K**.

Switch B selects input type **thermocouple** or **RTD** (resistance temperature detector). *Note:* If RTD is selected, switch A is ignored.

Switch C selects temperature units **°F** or **°C**.

Switch D selects either **PI** (Proportional-Integral) or **ON-OFF** control.

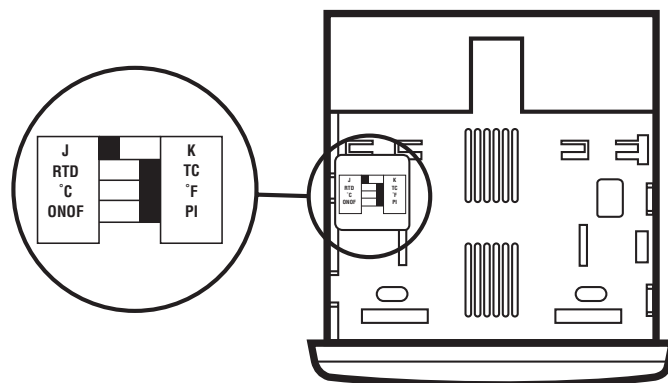

Figure 3.1
Default Dip Switch Settings

2110 Temperature Controller

Mounting

Two mounting collars securely hold the 2110 controller in the mounting hole. Remove these mounting collars before installation.

Removing Mounting Collars

1. To remove the rear collar, press the sides of the collar. This releases holding tabs on the top and bottom of the collar.
2. Slide the collar off the back of the unit.
3. Slide the front collar off the back of the unit

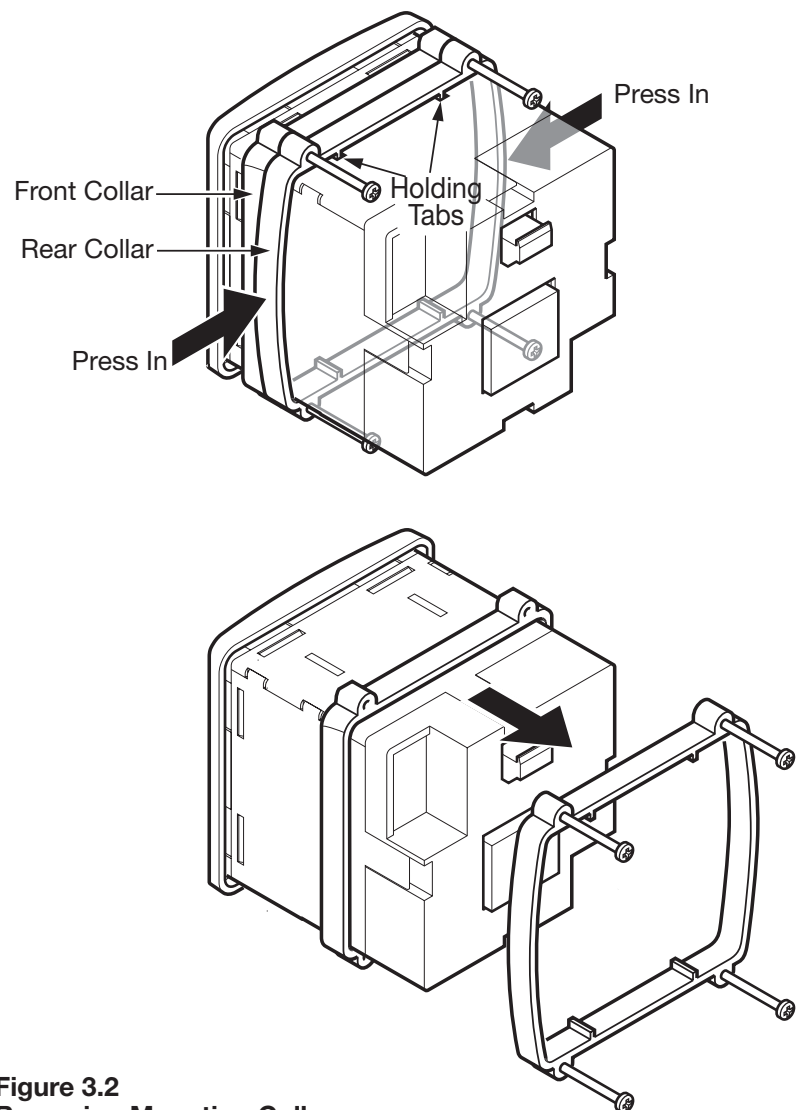

Figure 3.2
Removing Mounting Collars

continued

Chromalox®

Mounting *continued*

Mount the 2110

1. Cut out a 1/4 DIN, 3.6-inch (92mm) square hole in the mounting panel.
2. Insert the unit into the mounting hole as shown in Figure 3.4.
3. Slide the front mounting collar onto the back of the controller.
4. Slide the rear mounting collar onto the back of the controller until the holding tabs securely engage with the holding tab slots in the controller housing (see Figure 3.4).
5. Tighten the four rear collar mounting screws until the unit is held firmly in the panel. **CAUTION: Do not overtighten.**

The controller will now be held firmly in place.

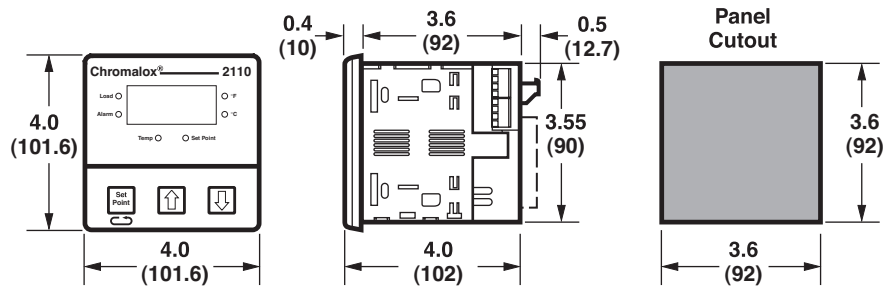

Figure 3.3
Mounting Dimensions

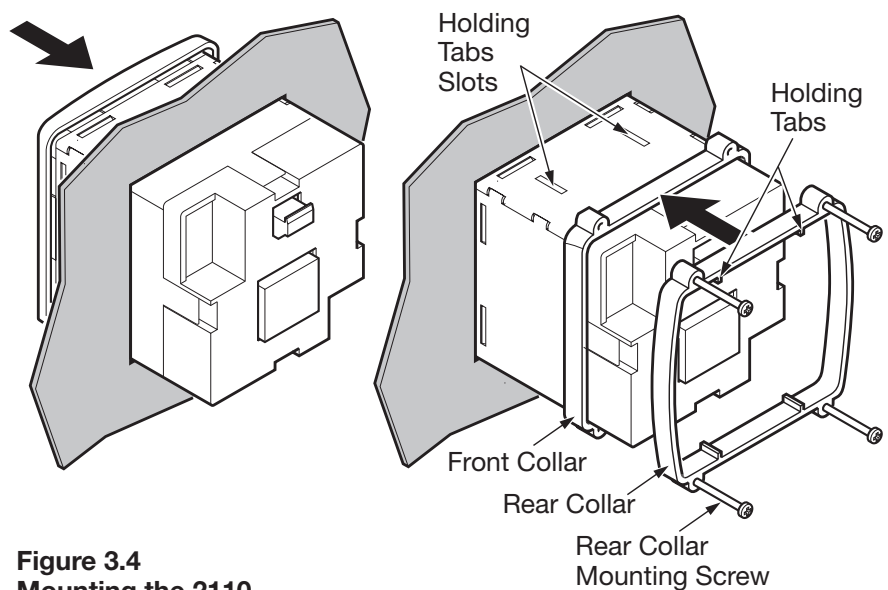

Figure 3.4
Mounting the 2110

2110 Temperature Controller

Good Wiring Practices

Separate wire into bundles—When planning the system wiring, separate wiring into functionally similar bundles, e.g.

- Power leads
- Sensor leads (if power leads must cross sensor leads, they should cross at a 90° angle)
- Output signal lines

Separate sources of electrical noise—Locate all sources of electrical noise in your system, and separate these sources from the control system, e.g.

- Motors
- Contacts
- Solenoids

Electrical noise can affect the function of any control system. When driving a contactor coil or other inductive load, an appropriate rated AC snubber circuit is recommended (Chromalox Part No. 0149-01305).

Connect before power is applied—Make all electrical wiring connections to the back of the controller before power is applied to the unit.



Comply with regulations—**WARNING: All wiring practices must comply with local regulations. Failure to do so could result in damage to controller and/or personal injury or death from electrical shock.**

This instrument is intended for panel mounting and the terminals must be enclosed within a panel. Use National Electric Code (NEC) Class 1 wiring for all terminals except the sensor terminals.

Check wiring decal—Check the wiring decal on the side of the unit to verify the model number. The wiring decal shows the wiring terminations. All wiring will be connected to the terminals on the back of the instrument case. Specific wiring instructions for different input and output types are given in this section. See also Figure 3.5.

Additional information—For sensor wiring practices, see “Sensor Input Wiring”. For additional information on good wiring practice, request IEEE Standard No. 518-1982 from IEEE, 345 East 47th St., New York, NY 10017 or www.ieee.org.

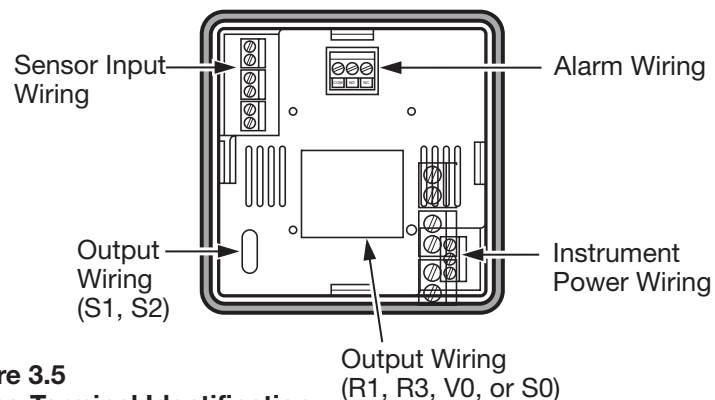

Figure 3.5
Wiring Terminal Identification

Chromalox®

Sensor Input Wiring

Sensor Wiring Notes

For safety and best controller performance,

- **Sensor leads** (thermocouple and RTD) should not be run in the same conduit as power wiring.
- **Twisted pair, shielded wire** is recommended for sensor connections.
- **False temperature readings** can occur if the sensor wire is exposed to electrical noise.
- **Ungrounded thermocouples** are recommended.
- **Thermocouple extension wire**, if required, must be the same type as the thermocouple (i.e. if a Type K thermocouple is used, then Type K extension wire must be used.)
- **Shielded thermocouple wire**, if used, must have the shield grounded at one end only, preferably at the shield ground terminal on the controller as shown in Figure 3.6.
- **Three-wire RTDs** are recommended for greatest accuracy.
- **Standard shielded copper wire** is recommended for RTD extensions.

Thermocouple Inputs

It is important to observe polarity (+,-) when connecting thermocouple leadwires. ANSI color coding for the thermocouples used with this instrument are

Thermocouple Type	Material	Polarity (+)	Polarity (-)
J	iron/constantan	white	red
K	chromel/alumel	yellow	red

Make thermocouple wiring connections to terminals as shown in Figure 3.6.

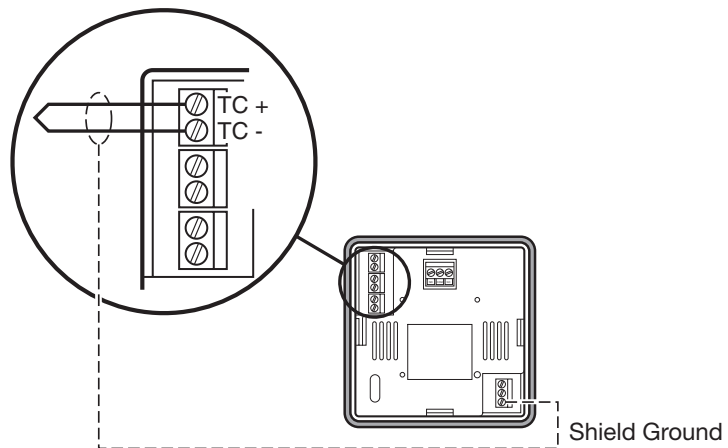

Figure 3.6
Thermocouple Connections with Shield

2110 Temperature Controller

Sensor Input Wiring

continued

Three-Wire RTD Inputs

IMPORTANT: When making the three-wire RTD input connection, make the resistance of all three extension leadwires equal by using the same gauge and same length of wire for optimum accuracy. A three-wire RTD will generally have two wires of the same color. Connect the same colored wires to the RTDL connections. Connect the alternate colored wire to the RTDH connection.

Make three-wire RTD connections to terminals as shown in Figure 3.7.

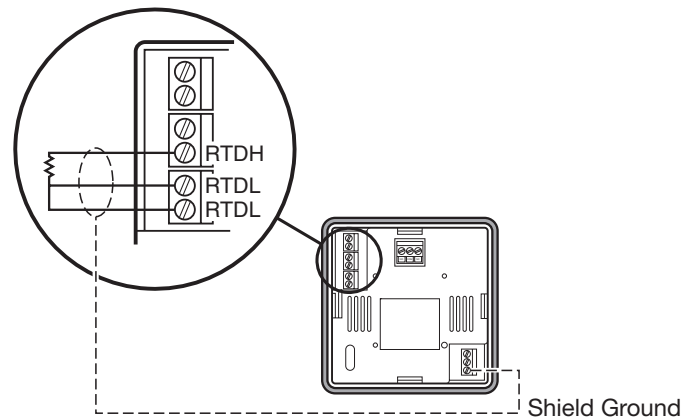

Figure 3.7
Three-Wire RTD Connections with Shield

Two-Wire RTD Inputs

If using a two-wire RTD input, use heavier gauge leadwires to reduce leadwire resistance. Any leadwire resistance adds directly to sensor resistance, thus adding error to the process temperature measurement. It is also necessary to jumper the two RTDL terminals on the instrument to complete a two-wire hookup.

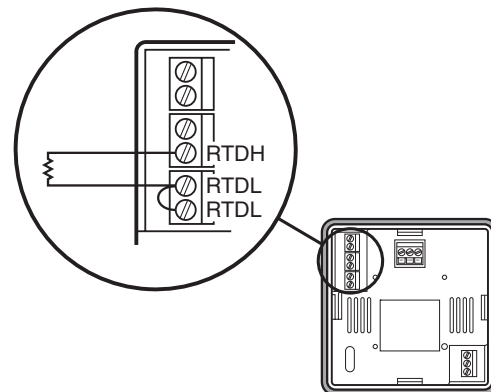

Figure 3.8
Two-Wire RTD Connections

Chromalox[®]

Control Output Wiring

The following figures show the proper control output wiring for the various 2110 configurations.

R1 (1 Amp Relay) and S0 (1 Amp, Solid State Relay) Output Wiring

When driving a contactor coil or other inductive load, an appropriately rated AC snubber circuit is recommended (Chromalox Part. No. 0149-01305), as shown in Figure 3.9.

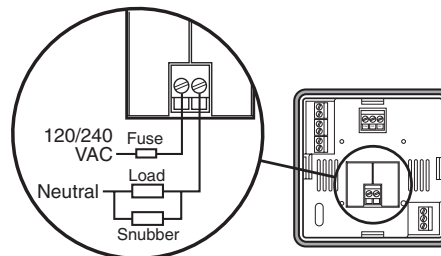

Figure 3.9
Control Output Wiring—R1 and S0

R3 (20 Amp Relay) Output Wiring

1/4" fast-on tabs are provided with the R3 output.

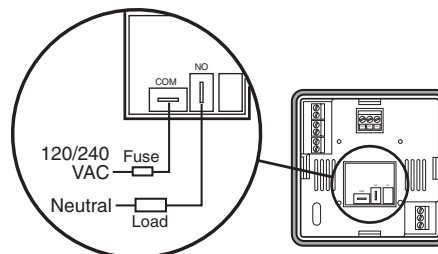

Figure 3.10
Control Output Wiring—R3

V0 (Solid State Relay Drive, 24Vdc, 40mA) Output Wiring

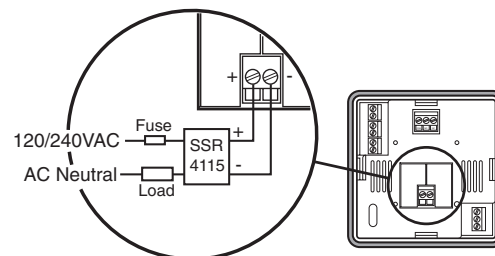

Figure 3.11
Control Output Wiring—V0

2110 Temperature Controller

Control Output Wiring *continued*

S1 (Solid State Relay, 5 Amps) and S2 (Solid State Relay, 10 Amps) Output Wiring

Note: 2110 model S2 has a fan. 2110 model S1 does not have a fan.

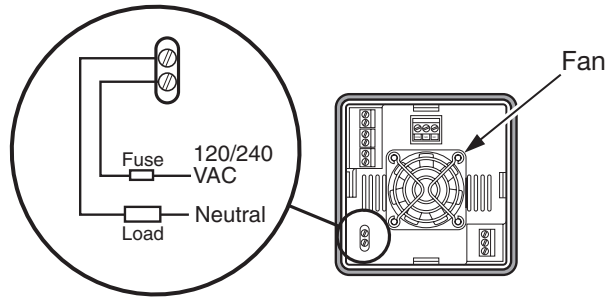

Figure 3.12
Control Output Wiring—S1 and S2

Instrument Power Wiring

Make 120 or 240 VAC instrument power connections to terminals as shown in Figure 3.13.

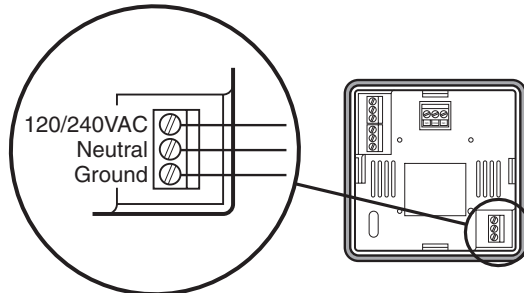

Figure 3.13
90-260 VAC Instrument Power Connections

Alarm Wiring

The Form C Relay Output is connected as shown in Figure 3.14.

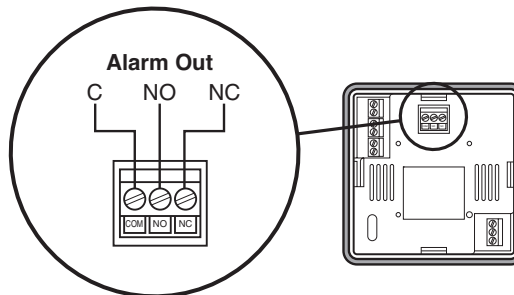

Figure 3.14
Alarm Connections

Chromalox®

Section 4—Adjusting Set Point and Configuration

Adjusting the Set Point

1. Set selection switches (see Figure 3.1).
2. Apply power to the unit.
3. To adjust the set point on the Chromalox 2110 Temperature Controller, press and hold the Set Point button (see Figure 4.1). The Set Point light is illuminated and the set point value is displayed.
4. While still pressing the Set Point button, press either the \uparrow or \downarrow button to adjust the set point to the desired value (see Figure 4.2).
5. Release the Set Point button.

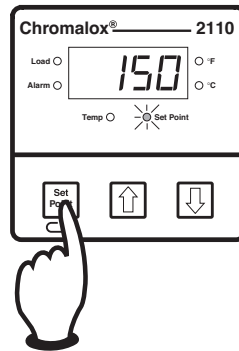

Figure 4.1
Establishing the Set Point

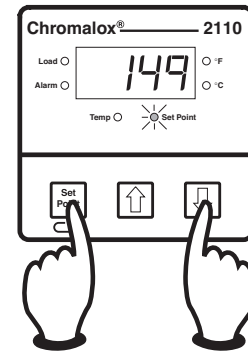

Figure 4.2
Adjusting the Set Point

Configuration

While the 2110 default settings make it a simple setup controller for most applications, additional programmable menus can be configured through three front-panel pushbuttons.

To access the user configuration menus,

1. Press and hold the \uparrow and \downarrow buttons. After three seconds the display will begin to toggle between the current security code and **Loch** (LOCK). The Temp and Set Point LEDs will turn on. See Figure 4.3.
2. Press the \uparrow or \downarrow button to adjust the value to the appropriate security number (see *Security Codes and Levels*). Only the value is displayed during adjustment. See Figure 4.4.
3. Press and hold the Set Point (\curvearrowright) button and press the \uparrow or \downarrow buttons to scroll the configuration menus. The display will show the name of the menu and then begin to toggle between the name and the current value. See Figures 4.5 and 4.6.

2110 Temperature Controller

Configuration *continued*

- Press the \uparrow or \downarrow buttons to adjust the value (only the value is displayed during adjustment). See Figure 4.7. The new value is set when the \uparrow or \downarrow button is released.
- Press and hold the Set Point (\hookrightarrow) button and press the \uparrow button to advance to the next menu. See Figure 4.8. (Holding the Set Point (\hookrightarrow) button and pressing the \downarrow button moves through menus in the opposite direction.)

Repeat steps 4 and 5 through the configuration menus.

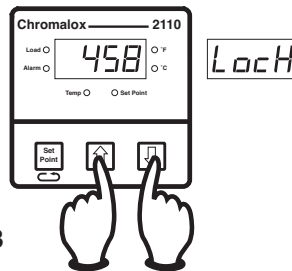

Figure 4.3

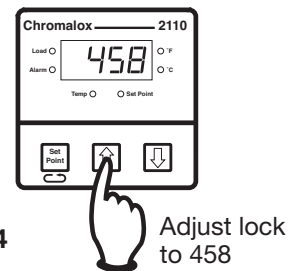

Figure 4.4

Adjust lock to 458

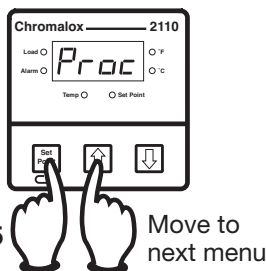

Figure 4.5

Move to next menu

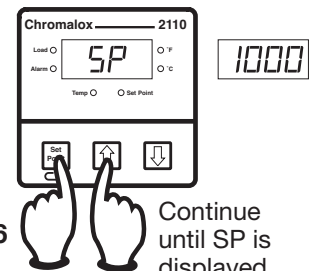

Figure 4.6

Continue until SP is displayed

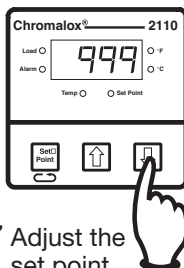

Figure 4.7

Adjust the set point value

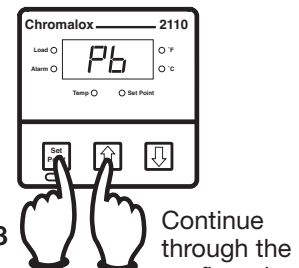

Figure 4.8

Continue through the configuration menus

Exit Configuration

To exit configuration mode, press and hold both the \uparrow and \downarrow buttons for three seconds to return to the operation mode.

Note: If no buttons are pressed for three minutes while in user configuration mode, then the controller will exit user configuration and return to the operation mode.

Chromalox®

Security Codes and Levels

To limit access to the user configuration interface, security codes are assigned to different menu levels. Make security codes available to operators, maintenance crew, supervisors, etc. according to what function level you want for each group. **Security Level C is not recommended for most users.** Gain access to configuration menus using the following codes.

Security Level	Security Code	Function
A	All Values	Allows adjustment of the Set Point
B	458	Basic menus
C	736	Calibration menus

Configuration Menus

The following configuration menus can be accessed through the user interface (see *Configuration*, page 12).

Menu Code	Function	Adjustable Range	Factory Default	Security Level
LOCK	Security Lock	0-999	458	A
PROC	Process Variable Display Displays the actual process temperature.	Read Only °F or °C	N/A	A
SP	Process Set Point Adjust Adjusts the target process temperature.	Sensor Range °F or °C	0°F	A
PB	Proportional Band Temperature range above/below set point where proportional control is active. Most applications require a band between 10 to 200°F. This menu is active only when the dip switch is set to "PI"	1 to Sensor Span Maximum °F or °C	25	B
ARST	Automatic Reset Control feature that automatically corrects for small temperature offsets that occur in proportional control. The higher the setting, the faster the correction occurs. A high setting could cause overshoot during start-up. A low setting will not allow process temperature to reach to set point quickly enough. A setting of "0" turns off automatic reset. This menu is active only when the dip switch is set to "PI".	0.0 to 100.0 Repeats/ Min.	0.1	

2110 Temperature Controller

Configuration Menus

continued

Menu Code	Function	Adjustable Range	Factory Default	Security Level
CYCL	Cycle Time The time for the output to complete ON to OFF to ON cycle. Used only with proportional control. A fast cycle time provides better control, but can cause premature wear to contactor or other power switching devices. Magnetic contactors should not be switched at less than a 30 second cycle time. This menu is active when the dip switch is set to "PI".	.1 to 60.0 Sec.	Output R1, R3 = 30 sec. S0, S1, S2, V0 = 1 sec.	B
DB	On/Off Dead Band The range above/below set point in which no control action takes place. Determines at what temperature the output switches ON and OFF. For a 5°F dead band, 2.5°F is above and below the set point. This menu is active when the dip switch is set to "ONOF".	1 to 100 °F or °C	5 Foc	B
ALTY	Alarm Type Select high or low alarm.	Off, Hi or Lo	OFF	B
ALSP	Alarm Set Point Temperature level that will actuate the alarm.	0 to 100 °F or °C	5	B
ALDB	Alarm Dead Band Difference of temperature from alarm set point before an active alarm resets.	0 to 100 °F or °C	5	B
SPLL	Set Point Lower Limit Lower limit to which set point may be set without security code access.	Sensor Range °F or °C	Span Low	B
SPUL	Set Point Upper Limit Upper limit to which set point may be set without security code access. This prevents an operator from setting the set point temperature to a level which would damage equipment or process.	Sensor Range °F or °C	Span High	B
OUTL	Output Limit Limits the percentage of output that can be applied in proportional control.	0 to 100%	100	B

**For calibration menus (CoFF, dFLt, & CALS), see Section 7–
Calibration**

Chromalox[®]

Section 5—Control and Alarm Operation

Control Operation

The 2110 is shipped from the factory with PI (proportional/integral) control. Proportional control actually determines the percent of heat needed to control the process. The factory setting for the Proportional Band is 25°F and the Automatic Reset (Integral) is set at 0.1 repeats/minute. These settings will control many processes without any changes to the controller. If the process is unstable or too sluggish, the Proportional Band and Automatic Reset can be changed in the menu configuration.

Tuning PI Control

Adjust Proportional Band The objective of the proportional band adjustment is to find the proportional band setting at which the process temperature stabilizes and does not oscillate. If the temperature display is oscillating, increase the Proportional Band (doubling the value) until the temperature display has stopped oscillating. To establish a quick response to control upsets, adjust for the smallest band that provides stable control (does not oscillate). *Note:* The temperature at this point may not be at set point, but will be stable.

Adjust Automatic Reset (Integral) The Automatic Reset (Integral) automatically removes the offset between process temperature and set point. If the process is too sluggish in approaching set point, double the automatic reset. Too much automatic reset will make a process unstable.

Cycle Time Cycle time setting determines how often to switch the output to the heater. For example, if the cycle time is 1 second and the 2110 needs a 75% output, the output will be on for 3/4 of a second and off 1/4 of a second. Units with relay control outputs (R1 or R3) are shipped with a 30-second cycle time. Units with solid state relays or solid state relay drives (S0, S1, S2, or V0) are shipped with a 1-second cycle time.

Alarm Operation (optional)

An alarm relay output is optional on the 2110. An alarm can help protect the process when a too high or too low temperature occurs.

High Alarm: This alarm is a high absolute alarm that actuates when the process temperature is equal to or greater than the alarm set point. For example, if the high alarm set point is 500°F, the alarm will always actuate when the process temperature reaches 500°F.

Low Alarm: The low absolute alarm actuates when the process temperature is equal to or less than the alarm set point. The low alarm features a power-up inhibit to prevent undesirable alarms during process start up. After the unit reaches control set point, the low alarm will respond.

Alarm Dead Band: The alarm relay de-energizes (resets) when the temperature crosses out of the alarm dead band. For example, if the high alarm is set to 500°F and the alarm dead band is 5°F, the alarm condition will not reset until the process temperature reaches 495°F.

To enable the alarm relay, select either high or low alarm type and set the alarm set point. An alarm condition is indicated when the *Alarm* light to the left of the display illuminates. Alarm type, set point, and dead band are selectable through the user configuration interface.

2110 Temperature Controller

Section 6—Replacing Output Modules

The Chromalox 2110 Temperature Controller was shipped with the output modules installed as ordered. The 10A Solid State Relay and 20A Mechanical Relay output cards control small cartridge heater or strip heater loads directly, eliminating the need for a remote contactor or solid state relay. If a larger load is required, the 2110 can be configured with a 1A Pilot Duty Relay or Solid State Relay Drive.

The 2110 may be optionally configured with a 5A/120V Alarm Relay. Alternate modules, configured with or without alarm, can be installed as needs change.

Control and alarm outputs can be changed in the field.

Module Option Descriptions

Output Module options are as follows

Description	Load/Sourcing Specification	Factory Default Cycle Time	Part No w/o Alarm	Part No. w/ Alarm
R1 Relay	Form A contact, SPST, N.O. 1.0 Amp at 120/240 VAC resistive load	30 sec.	0149-27133	0149-27147
R3 Relay	Form A contact, SPST, N.O. 20 Amp at 240 VAC, 28 VDC resistive load	30 sec.	0149-27132	0149-27146
V0 SSR Drive	24 VDC nominal at 40 mA	1 sec.	0149-27135	0149-27149
S1 TRIAC	1 amp continuous, 10 Amp in-rush 120/240 VAC	1 sec.	0149-27134	0149-27148
S1 Solid State Power Controller	120/240 VAC, 5 Amp @ 40°C ambient	1 sec.	0149-27136	0149-27150
S2 Solid State Power Controller	120/240 VAC, 10 Amp @ 40°C ambient with built-in cooling fan mounted on rear of housing	1 sec.	0149-00022 (Fan Kit)	0149-00022 (Fan Kit)

Module Installation



WARNING: Remove power from the controller before changing the output module. Failure to do so could cause damage to controller and/or personal injury or death from electrical shock.

When handling output modules, be careful to guard the module against static discharge. Follow the steps below to remove an existing output module and replace it with a new module.

Removal

1. Remove power from the controller.
2. Remove all terminal connections.

continued

Chromalox[®]

Module Installation

continued



3. Remove the back cover by lifting four housing clips on the controller. This releases the back cover. Then pull cover straight off the controller.
4. Gently pry around the sides to loosen and remove the module. Pull module straight out to avoid bending pin connections.

WARNING: Do not remove module by the handling components on the module board. This could damage the module.

When removing an S2 output module (SSR with fan), a cable connects the fan to the far right center of the S2 board. Gently disconnect the cable from the connector on the output board. **Do not remove the fan from the back cover. This is a single assembly.** For the S2 output module, reconnect the fan cable to the connector on the far right center of the module. Tuck the cable around the heatsink.

Replacement

1. Line up pins on the controller with pin connections on either side of the module and push the new module into place.
2. Reinstall the back cover.

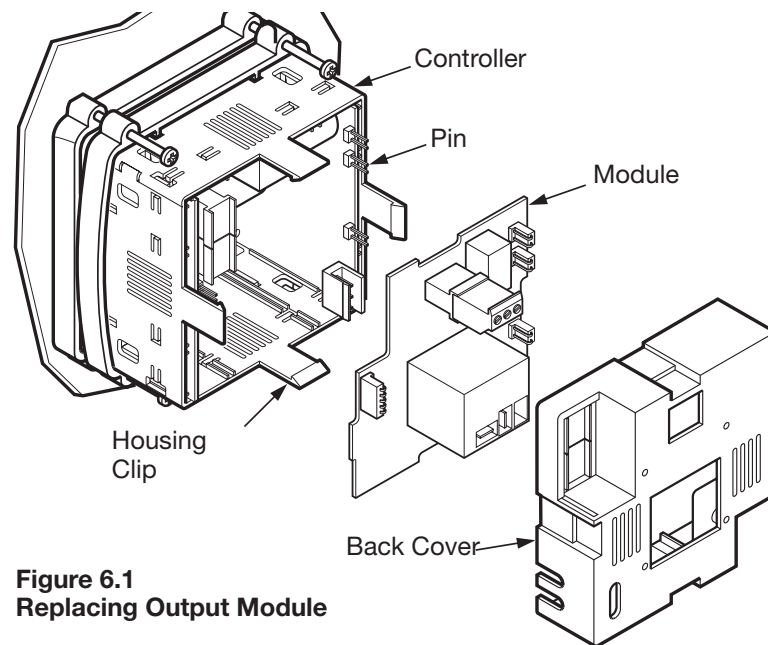

Figure 6.1
Replacing Output Module

Auto Cycle Time

The Control Output Modules have a default cycle time of 1 second (fast switching) or 30 seconds (slow switching) (See table on page 17). After replacing a control output, the 2110 verifies at power up if a slow or fast cycle time output has been installed. If an output with a different default cycle time is installed, the 2110 will change the cycle time to the new device's default. If the user has changed the cycle time in configuration, the 2110 retains this value unless an output with a different default cycle time has been installed.

2110 Temperature Controller

Section 7—Calibration

Calibration Offset

Calibration offset offsets the displayed value. Usually, this option is used to match displays of two different instruments that are measuring the same temperature, but are displaying different temperatures due to different thermocouple accuracy or placement of the thermocouples. Caution is advised when adding an offset to the display, since the actual sensed temperature will not be displayed.

Calibration offset (**coFF**) is available in the configuration mode, but only displays if the security lock (**LoCH**) is set to 736.

Factory Default Recovery

This option allow you to return the controller's configuration parameters back to the factory default values (except for the **LoCH** menu). This parameter could be used when moving a unit from one application to another to give the operator an easy place to begin setup of the unit.

Factory Default Recovery is performed in the Configuration Mode, menu **dFLt**. The security lock (**LoCH**) must be set to 736 to perform a factory default recovery.

To reestablish the factory default values:

1. Disconnect load power.
2. In the Configuration Mode, set security level (**LoCH**) to 736.
3. Go to menu **dFLt** and press **↑**. The controller will automatically reset the values. When the display cycles from **rEdy** to **donE**, the recovery is complete.

Calibration

The Chromalox 2110 Temperature Controller is factory calibrated before shipment. Recalibration is not needed when you receive and install the product. Periodic calibration checks or adjustments should not be necessary under normal operating conditions. Chromalox recommends you recalibrate the controller if all instruments in your facility are periodically calibrated to a known standard.

The 2110 always retains the original factory calibration values for the J, K, and RTD inputs. In an application, only one of these sensor inputs will be used. The 2110 only can retain manual calibration for a single sensor.

Calibration Notes:

continued

Chromalox®

Calibration

continued

When calibrating the 2110

1. You must have a sensor simulator to calibrate the 2110 controller. Substitute a precision sensor simulator (Thermocouple simulator or resistance simulator box) for sensor inputs.
2. Disconnect load power to prevent damage to the process or load.
3. Calibrate RTD inputs using copper (Cu) wire. Calibrate thermocouple inputs using thermocouple extension wire of the same type as the thermocouple you are calibrating.
4. Allow the controller to warm up with the appropriate sensor simulator connected for at least one hour prior to calibration.
5. To access the calibration menu, you need level C (736) security.

Sensor Calibration:

1. Set the 2110 selection switch to RTD or TC. If TC is selected, then set the selection switch to J or K.
2. Connect the sensor simulator to the sensor input terminals.
3. Set the simulator to the low value of the sensor selected J TC (-100°F), K TC (-100°F), RTD (-200°F or 48.46Ω).
4. Go to the **CALS** parameter on the 2110. The display will toggle between **CALS** and **inLo**.
5. Wait 30 seconds for the electronics to fully stabilize. Press **↑**. Dashes will appear in the display while the controller calibrates the low end of span.
6. When the controller prompts **inHi** in the display, adjust the sensor simulator to the high end of the selected sensor span. J TC (1400°F), K TC (2400°F), RTD (1000°F or 293.49Ω).
7. Wait 30 seconds for the electronics to fully stabilize. Press **↑**. Dashes will appear in the display while the controller calibrates the high end of span. When finished, the controller will display **donE**.
8. Calibration is complete.

Factory Calibration Recovery

This procedure allows you to return the controller to its factory calibration settings in the event it is severely out of calibration due to poor technique or unauthorized calibration.

1. Disconnect load power.
2. Cycle the sensor selection switch twice from its original position (TC or RTD) to the opposite position (RTD or TC) and back to its original position. This brings back the factory calibration and deletes the manual calibration settings.

2110 Temperature Controller

Section 8—Specifications

Control Modes	ON/OFF; PI—Proportional with integral		
Control Adjustments			
Proportional Band	1 to sensor span maximum		
Automatic Reset.....	0.0 to 100.0 repeats/minute		
Cycle Time.....	0.1 to 60.0 seconds		
On/Off Deadband	1° to 100°F or °C		
Set Point Upper Limit.....	sensor range °F or °C		
Set Point Lower Limit	sensor range °F or °C		
Output Limit.....	0 to 100%		
Alarm Adjustments			
Type.....	Absolute High or Low		
Set Point.....	Sensor range °F or °C		
Alarm Dead Band	0° to 100°F or °C		
Control/Alarm Outputs			
Relay (R1)	1 Amp Form A, 120/240VAC		
Relay (R3)	Form A, 120/240VAC resistive loads at 30 sec. cycle time		
	20 Amps, 500,000 Operations		
	15 Amps, 1 Million Operations		
	10 Amps, 5 Million Operations		
	5 Amps, 5 Million Operations		
Solid State Relay Drive (V0).....	24VDC at 40mA		
Solid State Relay (S0).....	1A Triac, up to 240VAC		
Solid State Relay (S1).....	5A, up to 240VAC at 40°C		
Solid State Relay (S2).....	10A, up to 240VAC at 40°C		
Alarm	Form C, Relay 5 Amps at 120VAC, 2.5A at 240VAC		
Sensor Input	Switch selectable; J,K Thermocouple; RTD		
Input Update Rate	Four samples per second		
Input Specifications	Range °F	Range °C	Accuracy at 77°F ambient
J TC	-100 to 1400°F	-73 to 760°C	0.2% Span +/-1 least significant digit
K TC	-100 to 2400°F	-73 to 1316°C	0.2% Span +/-1 least significant digit
100Ω Pt RTD (a=.00385)	-200 to 1000°F	-128 to 538°C	0.2% Span +/-1 least significant digit
Readout Stability			
J and K TC	+/-1°F per 10°F change in ambient temperature		
RTD	+/-0.5°F per 10°F change in ambient temperature		
Open Sensor and Out-of-Range Conditions			
Displays "SEnS", Control output 0%			
Instrument Power	90 to 260VAC Less than 10 VA		
Operating Environment	0° to 65°C (32° to 150°F)		
Dimensions			
Overall	4.0 x 4.0 x 4.0 inches (102 mm)		
Depth Behind Display.....	3.6 inches (92 mm)		
Front Panel Projection.....	0.4 inches (10 mm)		
Panel Cutout.....	3.6 x 3.6 inches (92 mm x 92 mm)		
Enclosure Material	High temp ABS plastic rated for 0° to 175°F		
Front Panel	NEMA 4X construction, requires surface finish not rougher than 0.000032 inch		
Influence of Line Voltage Variation ..	+/-0.1% of sensor span per 10% change in nominal line voltage		
Noise Rejection			
Common Mode Noise	Less than 2°F with 240 VAC, 60 Hz applied from sensor input to earth ground		
Series Mode Noise	Less than 2°F with 100mV, peak to peak series mode noise		
RFI	Typically less than 0.5% of sensor span at distance of 1 meter (3.1 feet) from a transmitter of 4W at 464MHz		
Sensor Leadwire Effect			
J Thermocouple	+1°F for 1000 ft. of 18 AWG thermocouple extension wire		
K Thermocouple.....	+2°F for 1000 ft. of 18 AWG thermocouple extension wire		
RTD	+/-0.1% of sensor span per 20Ω balanced leadwire resistance (20Ω is the total loop resistance)		

Chromalox®

Section 9—Troubleshooting

The following Troubleshooting Guide offers simple solutions to common problems and explains the 2110's Error Messages. Review this section for a possible solution to your problem before contacting Chromalox.

Note: For each symptom, perform correction steps in the order listed.

Symptom	Probable Cause	Correction Steps
Power applied, display does not light, and controller does not function	<ol style="list-style-type: none"> 1. No power applied 2. External fuse open 	<ol style="list-style-type: none"> 1. Check power wiring and fusing 2. Power down and repower up
Display alternates between HI and SENS , 2110 disables control output	<ol style="list-style-type: none"> 1. Open sensor 2. Out of calibration 	<ol style="list-style-type: none"> 1. Check sensor wiring 2. Check selection switches 3. To verify that controller is at fault, remove the thermocouple and place a jumper across the sensor terminals of the 2110. If the display reads approximately ambient, then the sensor is open. Replace the thermocouple. 4. See <i>Section 7—Calibration</i>
Process does not heat up	<ol style="list-style-type: none"> 1. No power being applied to the load 2. Load fuse open 	<ol style="list-style-type: none"> 1. Verify Load LED is ON 2. Verify the heater or fuse is not open 3. Verify output limit is set to 100% 4. Verify set point is greater than process temperature 5. Verify output wiring
Erratic operation	<ol style="list-style-type: none"> 1. Intermittent sensor connections 2. Controller failure (internal electronics) 3. External electrical noise 	<ol style="list-style-type: none"> 1. Check sensor wiring or substitute sensor simulator 2. Power down and repower up 3. Contact Chromalox

2110 Temperature Controller

Troubleshooting

continued

Symptom	Probable Cause	Correction Steps
Process not in control	<ol style="list-style-type: none">1. Incorrect settings2. Thermocouple Wiring	<ol style="list-style-type: none">1. Check Proportional Band setting and Automatic Reset setting2. Check thermocouple polarity
Instrument continually goes through power-up reset	<ol style="list-style-type: none">1. Severe electrical noise	<ol style="list-style-type: none">1. Separate sensor wiring from other wiring2. Apply power line filter3. Contact Chromalox

Limited Warranty:

Please refer to the Chromalox limited warranty applicable to this product at
<http://www.chromalox.com/customer-service/policies/termsofsale.aspx>.

Chromalox[®]
PRECISION HEAT AND CONTROL

1347 HEIL QUAKER BLVD., LAVERGNE, TN 37086
Phone: (615) 793-3900 www.chromalox.com