

2110

1/4 DIN Temperature Controller

- Easy Three-Step Setup
- High Current Output Option
 - 10 Amp Solid State Relay
 - 20 Amp Mechanical Relay
- Plug-In Output Cards
- J, K Thermocouple, or RTD Selectable Inputs, °F or °C Indication
- Alarm Relay Output Option
- NEMA 4X Front Panel
- Compact 1/4 DIN Design 4" Depth



Chromalox[®]
PRECISION HEAT AND CONTROL



Description

The Chromalox 2110 Temperature controller offers simple setup, flexibility and control features in an attractive, compact design that both OEMs and users will find cost effective. The 2110 is housed in a rugged, plastic 1/4 DIN package that only requires four inches behind the mounting surface. Straightforward operation and easy-to-use control features are major strengths of the 2110 controller.

Easy Three-Step Setup: The 2110 delivers exceptional process temperature control. Your process is up and running after three easy setup steps: 1) Select the sensor and control type, 2) Hook up the system and 3) Select the desired temperature.

Full Feature Outputs: A total of six output functions further extend the applications flexibility of the 2110 controller:

- 1 Amp Relay
- 20 Amp Relay
- Solid State Relay Drive
- 1 Amp Solid State Relay
- 5 Amp Solid State Relay
- 10 Amp Solid State Relay

The 2110 features a variety of output cards including High Current options of a 10 Amp Solid State Relay or 20 Amp Mechanical Relay. These outputs can directly control many cartridge or strip heaters, eliminating the need for a remote contactor or solid state relay. For larger three-phase loads, the 2110 can drive a remote device with the Pilot Duty Relay or Solid State Relay Drive outputs.

The optional Alarm Output gives you a non-latching, normally de-energized, 5 Amp relay output for over or under temperature protection of critical process temperatures.

Packaging with the User in Mind: The 2110 features a NEMA 4X front panel with tactile feedback push buttons. The buttons allow even the heaviest gloved hand to easily configure this controller. Large, bright LEDs provide an easy-to-read interface at a distance.

Flexibility: Output cards are plug-in modules that are field replaceable. The switch-selectable control modes include On-Off or Proportional-Integral (PI).

2110 Temperature Controller

Easy Three-Step Setup

1. Select Sensor and Control Type

Locate the input selection DIP switch on the bottom of the 2110 controller and simply select °F or °C, Thermocouple (TC) or RTD, the Thermocouple type (J or K), and PI (Proportional-Integral) or onof (on-off) control.

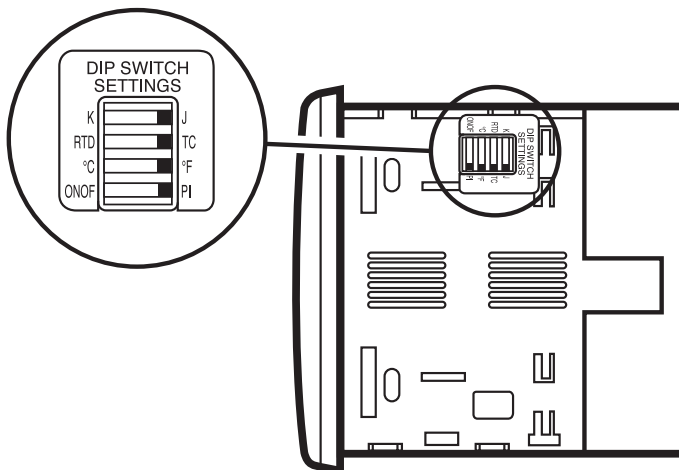

2. Hook Up System

Connect system wiring to 2110 controller for the load, sensor and optional alarm output if used.

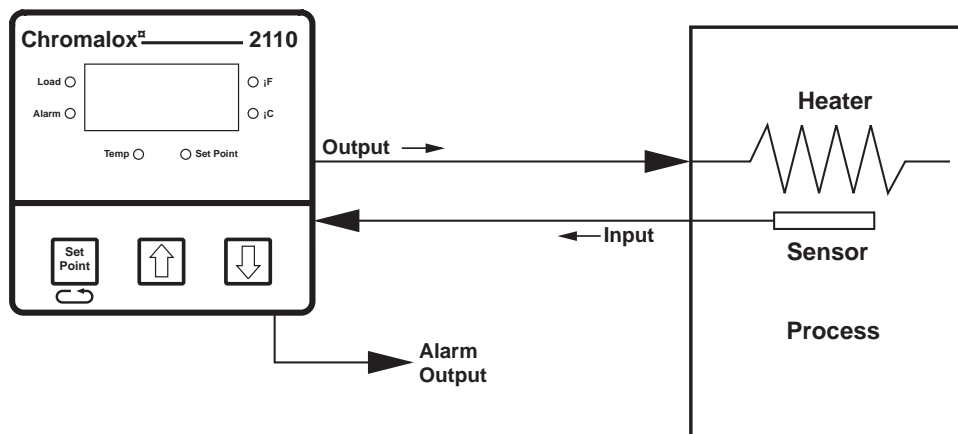

3. Select Temperature

Press and hold the Set Point key while using the Up or Down arrow keys to adjust the Set Point to the proper value.

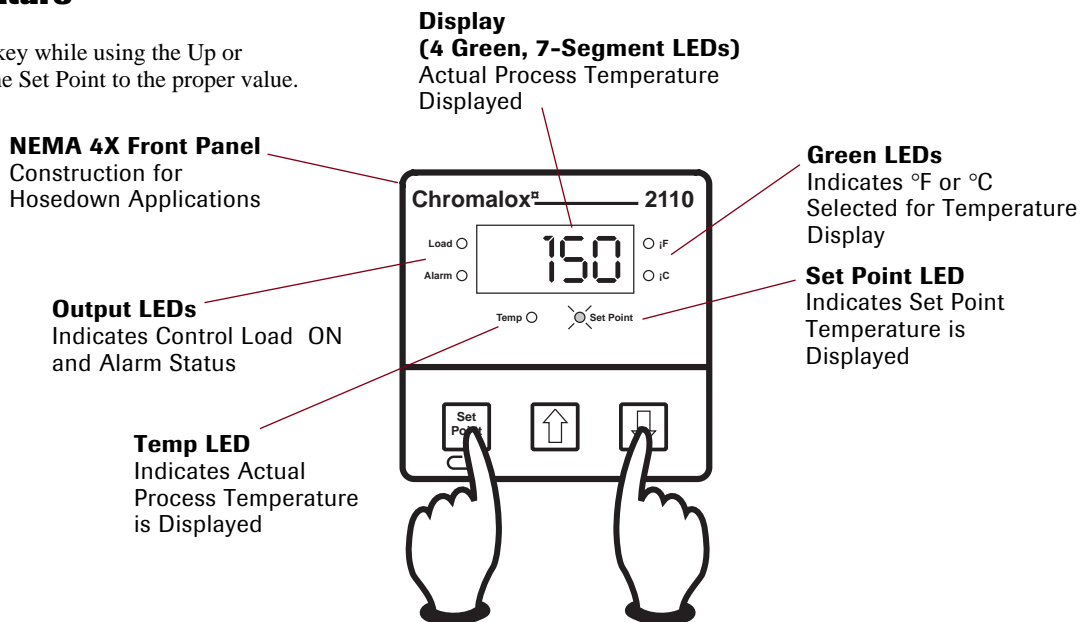

2110 Temperature Controller

Features

High-Current Switching

The 2110 features high current output switching (Relay and Solid State Relay) eliminating the need for an external power switching device and reducing installation cost. Single phase loads up to 20 amps may be directly connected to the 2110, eliminating the need for a remote contactor or solid state relay. The internal relay option R3 can switch up to 20 amps or the internal solid state relay option S2 can switch up to 10 amps. The 2110 automatically detects the output type and adjusts the controllers setting for optimal control.

Control Modes

The 2110 provides precise, solid state proportion control with automatic reset (PI) that will control precisely most heating applications. ON/OFF control may be selected for applications where maximum output life (load switching) is needed.

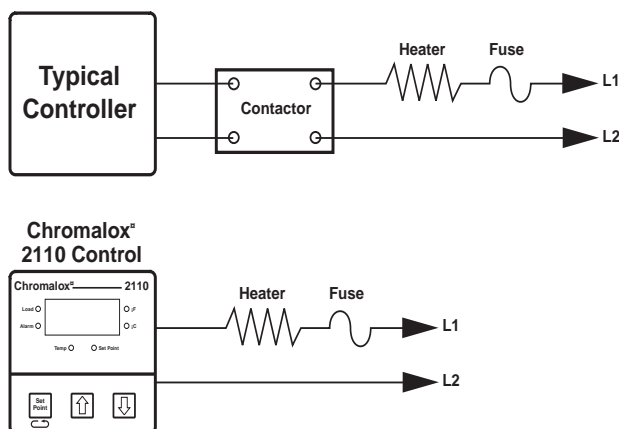

Specifications

Control Modes

- ON/OFF
- PI—Proportional with integral

Control Adjustments

- Proportional Band Sensor range
- Automatic Reset 0.0 to 99.9 repeats/minute
- Cycle Time 0.1 to 60.0 seconds
- On/Off Deadband 1° to 100°F or °C
- Set Point Upper Limit Sensor range °F or °C
- Set Point Lower Limit Sensor range °F or °C
- Output Limit 0 to 100%

Alarm Adjustments

- Type Absolute High or Low
- Set Point Sensor range °F or °C
- Alarm Dead Band 0° to 100°F or °C

Control/Alarm Outputs

- Relay (R1) 1 Amp Form A, 120/240VAC
- Relay (R3) Form A, 120/240VAC resistive loads at 30 sec. cycle time
20 Amps, 500,000 Operations
15 Amps, 1 Million Operations
10 Amps, 5 Million Operations
5 Amps, 5 Million Operations
- Solid State Relay Drive(V0) 24 VDC at 40mA
- Solid State Relay (S0) 1A Triac, up to 240VAC
- Solid State Relay (S1) 5A, up to 240VAC at 40°C
- Solid State Relay (S2) 10A, up to 240VAC at 40°C
- Alarm Form C, Relay 5 Amps at 120VAC, 2.5A at 240VAC

Sensor Input Switch selectable J, K Thermocouple or RTD

Input Update Rate Four samples per second

Readout Stability

- J and K TC +/-1°F per 10°F change in ambient temp.
- RTD +/-0.5°F per 10°F change in ambient temp.

Input Specifications

- | | Range °F | Range °C |
|------------------------|----------------|----------------|
| J TC | -100 to 1400°F | -73 to 760°C |
| K TC | -300 to 2400°F | -184 to 1316°C |
| 100Ω Pt RTD (α=.00385) | -200 to 1000°F | -128 to 538°C |

Open Sensor and

Out-of-Range Conditions Displays “SEnS”, Control output 0%

Instrument Power 90 to 260VAC Less than 10 VA

Operating Environment 0° to 65°C (32° to 150°F)

Enclosure Material High Temp ABS plastic rated for 0° to 175 °F

Front Panel NEMA 4X construction

Influence of Line

Voltage Variation +/-0.1% of sensor span per 10% change in nominal line voltage

Noise Rejection

- Common Mode Noise Less than 2°F with 230 VAC, 60 Hz applied from sensor input to earth ground
- Series Mode Noise Less than 2°F with 100mV, peak to peak series mode noise
- RFI Typically less than 0.5% of sensor span at distance of 1 meter (3.1 feet) from a transmitter of 4W at 464MHz

Sensor Leadwire Effect

- J Thermocouple +1°F for 1000 feet of 18 AWG thermocouple extension wire
- K Thermocouple +2°F for 1000 feet of 18 AWG thermocouple extension wire
- RTD +/-0.1% of sensor span per 20Ω balanced leadwire resistance

Termination Wiring

- Power, Input, Outputs (R1, VO, SO) #14-28 Stranded or Solid
- Outputs (S1,S2) #10-24 Stranded or Solid
- Outputs (R3) Quick Connect: 0.25 in (6.25mm)

Accuracy at 77°F ambient

- 0.2% span +/- 1 LSD
- 0.2% span +/- 1 LSD
- 0.2% span +/- 1 LSD

2110 Temperature Controller

Mounting Dimensions

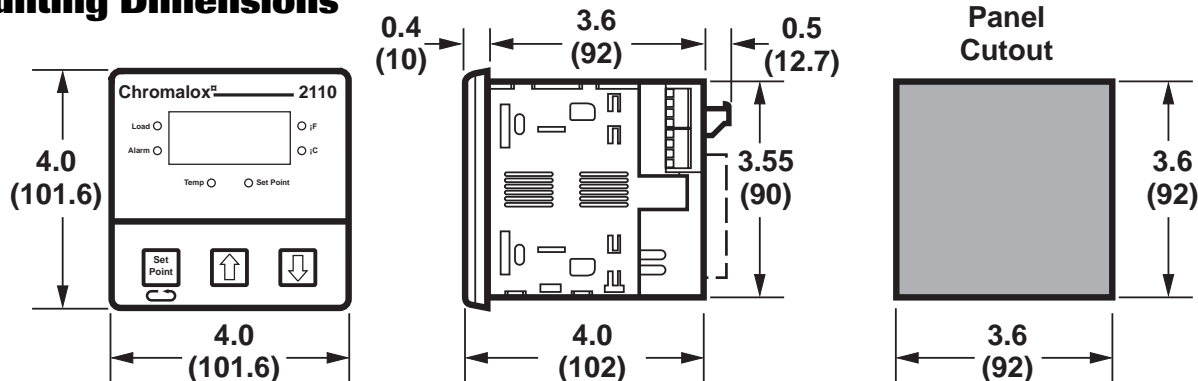

All dimensions in inches (mm)

* With alarm option or S2 output

Ordering Information

Model

2110 1/4 DIN Controller, with Selectable Thermocouple or RTD Inputs

Code Control Output

- R1 Relay, 1 Amp Form A, 120/240 Vac
- R3 Relay, 20 Amps Form A, 120/240 Vac
- V0 Solid State Relay Drive, 24 Vdc @ 40ma
- S0 Solid State Relay, 1 Amp, up to 240 Vac
- S1 Solid State Relay, 5 Amps, up to 240 Vac, at 40°C
- S2 Solid State Relay, 10 Amps, up to 240 Vac, at 40°C

Code Alarm Output (Kit Option)

- 0 No Alarm
- 1 Form "C" Relay, 5 Amps at 120 Vac, 2.5 Amps at 240 Vac

Code

- 0 Add to Complete Part Number

Code Power Supply

- 0 90-260 Vac

2110 - R3 1 0 0 Typical Model Number

Models	OrderCode	Spare Parts	Order Code
2110-R10000, 1Amp Relay	317016	0149-27147, R1 1Amp relay + Alarm	317139
2110-R1100, 1Amp Relay, Alarm	317075	0149-27146, R3 20Amp relay + Alarm	317147
2110-R3000, 20Amp Relay	317024	0149-27149, V0 SSR Drive Out + Alarm	317155
2110-R3100, 20Amp Relay, Alarm	317083	0149-27148, S1 1Amp triac + Alarm	317163
2110-V0000, SSR Drive	317032	0149-27150, S2 or S3 5, 10Amp SSR + Alarm	317171
2110-V0100, SSR Drive, Alarm	317091	0149-27133, R1 1Amp relay	317180
2110-S0000, 1Amp SSR	317040	0149-27132, R3 20Amp relay	317198
2110-S0100, 1Amp SSR, Alarm	317104	0149-27135, V0 SSR Drive Out	317200
2110-S1000, 5Amp SSR	317059	0149-27134, S1 1Amp triac	317219
2110-S1100, 5AmpSSR, Alarm	317112	0149-27136, S2 or S3 5, 10Amp SSR	317227
2110-S2000 10Amp SSR	317067	0149-00022, Fan Kit	317235
2110-S2100, 10Amp SSR, Alarm	317120		

PDS 2110
April 01
0037-75408